



18 - CD25D1 - 2

Available in French Canadian (FC)

Installer's Guide

Upflow/ Horizontal, Gas-Fired, Direct Vent, 2-Stage Condensing Furnaces with Variable Speed Inducer and Whole House Air Cleaner

*UX2B060AFV3VA

*UX2C100AFV4VA

*UX2B080AFV3VA

*UX2D120AFV5VA

* __First letter may be "A" or "T"

ALL phases of this installation must comply with NATIONAL, STATE AND LOCAL CODES



IMPORTANT — This Document is **customer property** and is to remain with this unit. Please return to service information pack upon completion of work.



 AIR FLOW UPFLOW/HORIZONTAL

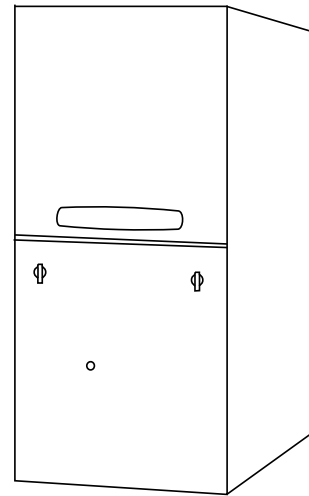
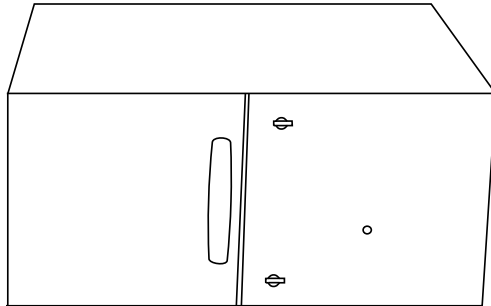

 AIR FLOW UPFLOW

Bottom Return ONLY

This unit is equipped with an integrated high efficiency Whole House Air Cleaner. Careful consideration must be taken in the installation process to avoid personal injury, property damage or equipment damage. These instructions do not cover all variations in systems or provide for every possible contingency. Should further information be desired or particular problems arise which are not covered sufficiently by this manual, contact your local distributor or the manufacturer as listed on the Furnace nameplate.

In addition, these Furnaces are suitable for installation in an attic, garage or crawl space with ducted supply and return air.

Safety signal words are used to designate a degree or level of seriousness associated with a particular hazard. The signal words for safety markings are **WARNING**, and **CAUTION**.

- a. **WARNING** indicates a potentially hazardous situation which, if not avoided, could result in death or serious injury.
- b. **CAUTION** indicates a potentially hazardous situation which, if not avoided, may result in minor or moderate injury. It is also used to alert against unsafe practices and hazards involving only property damage.

Installer's Guide

SAFETY SECTION

WARNING

CARBON MONOXIDE POISONING HAZARD

Failure to follow the steps outlined below for each appliance connected to the venting system being placed into operation could result in serious carbon monoxide poisoning or death.

The following steps shall be followed for each appliance connected to the venting system being placed into operation while all other appliances connected to the venting system are not in operation.

1. Seal any unused openings in the venting system.
2. Inspect the venting system for proper size and horizontal pitch, as required in the National Fuel Gas Code, ANSI Z223.1/NFPA 54 or the CSA B149.1 *Natural Gas and Propane Installation Code* and these instructions. Determine that there is no blockage or restriction, leakage, corrosion and other deficiencies which could cause an unsafe condition.
3. As far as practical, close all building doors and windows and all doors between the space in which the appliance(s) connected to the venting system are located and other deficiencies which could cause an unsafe condition.
4. Close fireplace dampers.
5. Turn on clothes dryer and any appliance not connected to the venting system. Turn on any exhaust fans, such as range hoods and bathroom exhausts, so they are operating at maximum speed. Do not operate a summer exhaust fan.
6. Follow the lighting instructions. Place the appliance being inspected into operation. Adjust the thermostat so appliance is running continuously.
7. Test for spillage from draft hood equipped appliances at the draft hood relieve opening after 5 minutes of main burner operation. Use the flame of a match or candle.
8. If improper venting is observed during any of the above tests, the venting system must be corrected in accordance with the National Fuel Gas Code, ANSI Z221.1/NFPA 54 and/or CSA B149.1 *Natural Gas and Propane Installation Code*.
9. After it has been determined that each appliance connected to the venting system properly vents where tested as outlined above, return doors, windows, exhaust fans, fireplace dampers and any other gas-fired appliances to their previous condition of use.

WARNING

Failure to follow the safety warnings exactly could result in a fire or explosion causing property damage, personal injury or loss of life.

-- Do not store or use gasoline or flammable vapors and liquids in the vicinity of this or any other appliance.

-- WHAT TO DO IF YOU SMELL GAS

- Do not try to light any appliance
- Do not touch any electrical switch;

do not use any phone in your building

• Immediately call your gas supplier from a neighbor's phone. Follow the gas supplier's instructions.

- If you cannot reach your gas supplier.

call the fire department.

-- Installation and service must be performed by a qualified installer, service agency or the gas supplier.

WARNING

FIRE OR EXPLOSION HAZARD

Failure to follow the safety warnings exactly could result in serious injury, death or property damage.

Improper servicing could result in dangerous operation, serious injury, death, or property damage.

The following safety practices and precautions must be followed during the installation, servicing, and operation of this Furnace.

1. Use only with the type of gas approved for this Furnace. Refer to the Furnace rating plate.
2. Install this Furnace only in a location and position as specified in "Location and Clearances" (page 4) of these instructions.
3. Provide adequate combustion and ventilation air to the Furnace space as specified in "Air for Combustion and Ventilation" (page 9), of these instructions.
4. Combustion products must be discharged outdoors. Connect this Furnace to an approved vent system only, as specified in the "Venting" section (pages 11-23), of these instructions.
5. Never test for gas leaks with an open flame. Use a commercially available soap solution made specifically for the detection of leaks to check all connections, as specified in the "Gas Piping" section of these instructions on page 31.
6. Always install the Furnace to operate within the Furnace's intended temperature-rise range with a duct system which has an external static pressure within the allowable range, as specified on the unit rating plate. Airflow with temperature rise for cfm versus static is shown in the Service Facts accompanying this Furnace.

Contents

7. When a Furnace is installed so that supply ducts carry air circulated by the Furnace to areas outside the space containing the Furnace, the return air shall also be handled by a duct(s) sealed to the Furnace casing and terminating outside the space containing the Furnace.
8. A gas-fired Furnace for installation in a residential garage must be installed as specified in "Location and Clearances" section (page 4) , of these instructions.
9. The Furnace may be used for temporary heating of buildings or structures under construction only when the following conditions have been met:
 - a. The Furnace venting system must be complete and installed per manufacturers instructions.
 - b. The Furnace is controlled only by a room Comfort Control (no field jumpers).
 - c. The Furnace return air duct must be complete and sealed to the Furnace.
 - d. The Furnace input rate and temperature rise must be verified to be within nameplate marking.
 - e. 100% of the Furnace combustion air requirement must come from outside the structure.
 - f. The Furnace return air temperature range is between 55° and 80° Fahrenheit.
 - g. Clean the Furnace, duct work, and components upon substantial completion of the construction process, and verify Furnace and whole house air cleaner operating conditions including ignition, input rate, temperature rise and venting, according to the manufacturer's instructions.
 - h. Remove the Whole House Air Cleaner and store in clean dry location during the construction process. To be reinstalled when construction is complete. See page 39 for proper air cleaner removal.
 - i. An external field supplied air filter must be used during construction.

10. This product must be gas piped by a Licensed Plumber or Gas Fitter in the Commonwealth of Massachusetts.

CAUTION

To prevent shortening its service life, the Furnace should not be used as a "Construction Heater" during the finishing phases of construction until the requirements listed in item 9, a-i of the safety section of this publication have been met. Condensate in the presence of chlorides and fluorides from paint, varnish, stains, adhesives, cleaning compounds, and cement create a corrosive condition which may cause rapid deterioration of the heat exchanger.

CAUTION

Chemicals used to during construction may cause damage to the COLLECTION CELL.

| | |
|--|-----------|
| Safety Section | 2 |
| Installation Instructions | 4 |
| General | 4 |
| Location and Clearances | 4 |
| Outline Drawings | 6 |
| Upflow Installation | 7 |
| Horizontal Installation | 7 |
| Air For Combustion and Ventilation | 9 |
| Duct Connections | 10 |
| General Venting | 11 |
| Venting Materials | 12 |
| Vent Tables | 15 |
| Horizontal Venting Through Wall | 17 |
| Venting Through The Roof | 19 |
| Venting Routed Through a Masonry Chimney | 20 |
| Downward Venting | 22 |
| Condensate Drain Instructions | 24 |
| Field Wiring Diagrams | 26 |
| Electrical Connections | 31 |
| Gas Piping | 31 |
| Combustion and Input Check | 33 |
| High Altitude Derate | 34 |
| Start-up and Adjustment | 35 |
| Preliminary Inspections | 35 |
| Lighting Instructions | 35 |
| Sequence of Operation | 36 |
| Control and Safety Switch Adjustments | 36 |
| Conditions Affecting System Operation | 38 |
| Whole House Air Cleaner Maintenance | 39 |
| IFC Error Flash Codes | 41 |
| Checkout Procedure | 43 |

WARNING

DO NOT USE SEMI-RIGID METALLIC GAS CONNECTORS (FLEXIBLE GAS LINES) WITHIN THE FURNACE CABINET.

FAILURE TO FOLLOW THIS WARNING COULD RESULT IN PROPERTY DAMAGE, PERSONAL INJURY OR DEATH.

Installer's Guide

GENERAL INSTALLATION INSTRUCTIONS

The manufacturer assumes no responsibility for equipment installed in violation of any code or regulation.

It is recommended that Manual J of the Air Conditioning Contractors Association (ACCA) or A.R.I. 230 be followed in estimating heating requirements. When estimating heating requirements for installation at Altitudes above 2000 ft., remember the gas input must be reduced (See combustion and input check page 31).

Material in this shipment has been inspected at the factory and released to the transportation agency without known damage. Inspect exterior of carton for evidence of rough handling in shipment. Unpack carefully after moving equipment to approximate location. If damage to contents is found, report the damage immediately to the delivering agency.

Codes and local utility requirements governing the installation of gas fired equipment, wiring, plumbing, and flue connections must be adhered to. In the absence of local codes, the installation must conform with latest edition of the National Fuel Gas Code ANSI Z223.1 • National Installation Code, CAN/CGA B149.1. The latest code may be obtained from the American Gas Association Laboratories, 400 N. Capitol St. NW, Washington D.C. 20001.

1-800-699-9277 or www.aga.org

These Furnaces have been classified as CATEGORY IV furnaces in accordance with latest edition of ANSI Z21.47 standards • CSA 2.3. Category IV furnaces operate with positive vent static pressure and with a flue loss less than 17 percent. These conditions require special venting systems, which must be gas tight and water tight. These Category IV Direct Vent Furnaces are approved for installation in Manufactured/ Mobile housing when used with BAYMFGH001A.

LOCATION AND CLEARANCES

WARNING

Do NOT install the Furnace directly on carpeting, tile or other combustible material other than wood flooring.

CAUTION

Do NOT install the Furnace in a corrosive or contaminated atmosphere.

Failure to follow this warning could result in early equipment failure.

The location of the Furnace is normally selected by the architect, the builder, or the installer. However, before the Furnace is moved into place, be sure to consider the following requirements:

1. Is the location selected as near the chimney or vent and as centralized for heat distribution as practical?

2. Do all clearances between the Furnace and enclosure equal or exceed the minimums stated in Clearance Table on the Outline Drawings?
3. Is there sufficient space for servicing the Furnace and other equipment? A minimum of 24 inches front accessibility to the Furnace must be provided. Any access door or panel must permit removal of the largest component.
4. Are there at least 3 inches of clearance between the Furnace combustion air openings in the front panel and any closed panel or door provided?
5. Are the ventilation and combustion air openings large enough and will they remain unobstructed? If outside air is used, are the openings set above the highest snow accumulation level? (See the Air for Combustion and Ventilation section, page 8)
6. **A heavy gauge steel plate is attached to the bottom of the unit for protection during shipping and handling prior to the unit installation. Leave this plate in place until the unit is ready to be connected to the ductwork.**
7. A Pre-filter is not required to be installed with the furnace containing a Whole House Air Cleaner. If the use of a Pre-Filter is desired, it must be installed at least 6" away from the Whole House Air Cleaner. The additional pressure drop of the Pre-Filter must be considered during duct design or evaluation to ensure proper airflow.
8. Allow sufficient height in supply plenum above the Furnace to provide for cooling coil installation, if the cooling coil is not installed at the time of this Furnace installation.

IMPORTANT:

The Furnace must be installed level. The only allowable variation would be slightly to the left and/ or forward in upflow installations or slightly toward the front in horizontal installations. This is necessary for proper condensate drainage.

9. A Furnace shall be installed so electrical components are protected from water.
10. DO NOT use silicon based sealant in the airstream. This causes a coating on the FIELD CHARGER pins that will decrease the efficiency of the air cleaner.
11. Allow a minimum of 24 inches clearance in front of the air cleaner to permit removal of COLLECTION CELL and FIELD CHARGER.
12. Do Not install furnace where the air cleaner can be exposed to UV light.

NOTE: Do NOT install an atomizing style humidifier in the return plenum of this unit.

13. Flow-through Bypass Humidifiers

Excessive bypass air may cause water blow-off, which will adversely affect system operation and air cleaner performance. To verify bypass airflow, follow the Bypass Humidifier Pre-Installation Check-out and Set-Up Procedures available through your local distributor. Ask for publication number 18-CH37D1-1.

Steam and Flow-through Fan Power Duct-mounted Humidifiers

Follow the humidifier installation instructions. These should only be installed on the supply air side of the system.

Other Duct Mounted Humidifiers are not recommended for installation with the air cleaner.

14. If the Furnace is installed in a **residential garage**, it must be installed so that the burners, and the ignition source are located not less than 18 inches above the floor and the Furnace must be located or protected to avoid physical damage from vehicles.
15. The whole house air cleaner is designed to run at a maximum indoor relative humidity of 65%.

Figure 1. COMPONENTS OF THE INTEGRATED WHOLE HOUSE AIR CLEANER

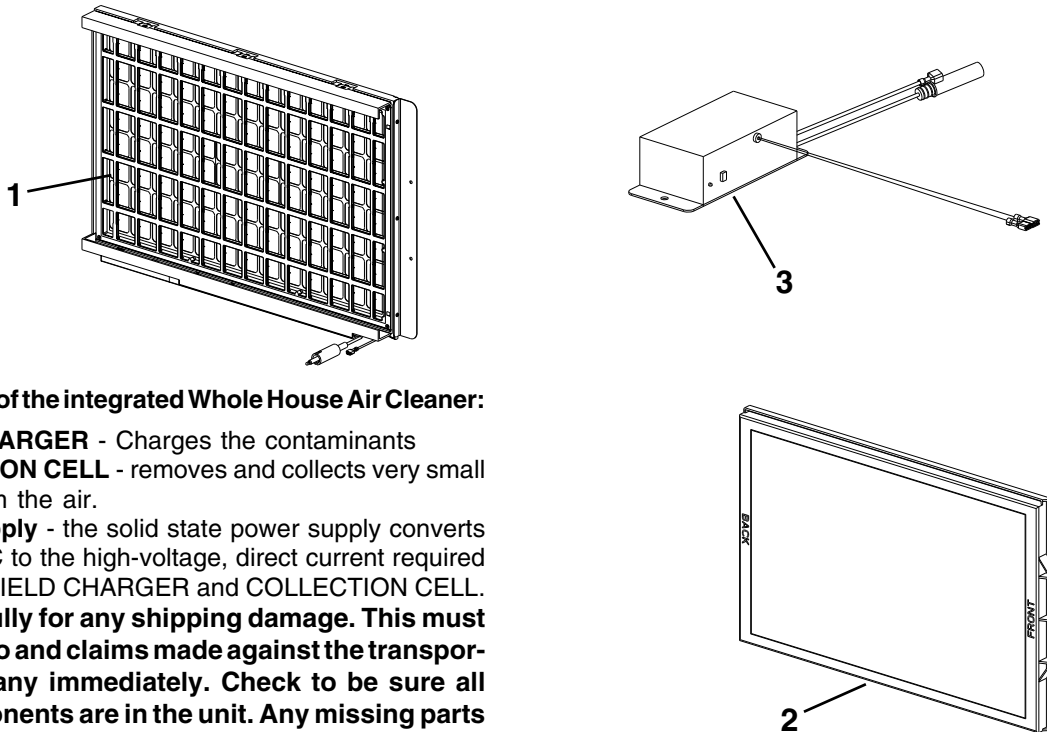

Components of the integrated Whole House Air Cleaner:

- 1) **FIELD CHARGER** - Charges the contaminants
 - 2) **COLLECTION CELL** - removes and collects very small impurities from the air.
 - 3) **Power Supply** - the solid state power supply converts the 24 Volt AC to the high-voltage, direct current required to power the FIELD CHARGER and COLLECTION CELL.
- Check carefully for any shipping damage. This must be reported to and claims made against the transportation company immediately. Check to be sure all major components are in the unit. Any missing parts should be reported to your supplier at once, and replaced with authorized parts only.**

*UX2 UPFLOW/HORIZONTAL OUTLINE DRAWING (ALL DIMENSIONS ARE IN INCHES)

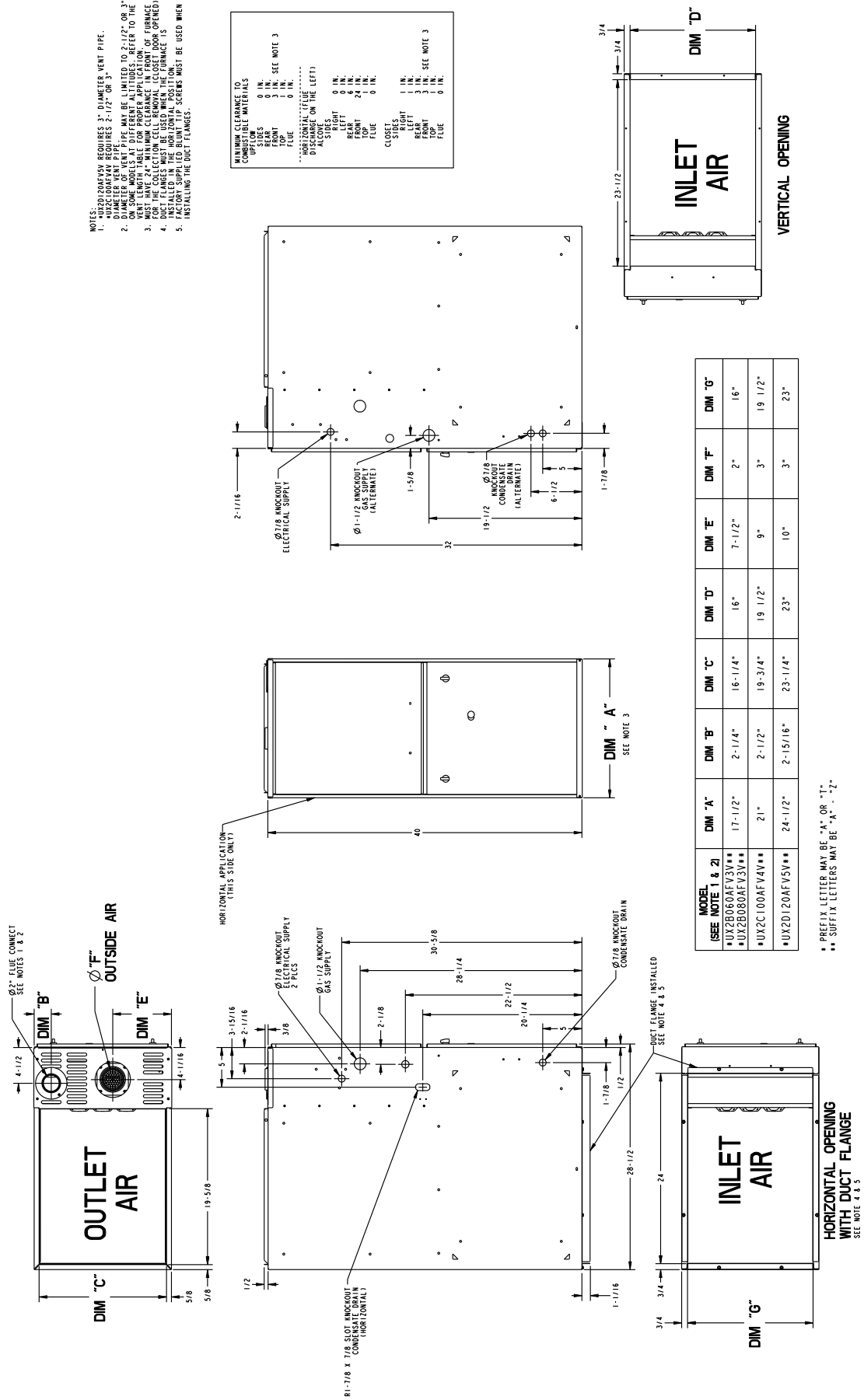

| MODEL (SEE NOTE 1 & 2) | DIM "A" | DIM "B" | DIM "C" | DIM "D" | DIM "E" | DIM "F" | DIM "G" |
|------------------------|---------|----------|---------|---------|---------|---------|---------|
| *UX2B060AEV3V** | 17-1/2" | 2-1/4" | 16-1/4" | 16" | 7-1/2" | 2" | 16" |
| *UX2B080AEV3V** | 21" | 2-1/2" | 19-3/4" | 19-1/2" | 9" | 3" | 19-1/2" |
| *UX2C100AEV4V** | 24-1/2" | 2-15/16" | 23-1/4" | 23" | 10" | 3" | 23" |

** PREFIX LETTER MAY BE "A" OR "T"
** SUFFIX LETTERS MAY BE "A" - "Z"

INSTALLATION INSTRUCTIONS

⚠ CAUTION

Bottom panel for furnace to remain in place until unit reaches final installation location. If bottom panel is removed before installation the COLLECTION CELL and FIELD CHARGER must also be removed to protect installation personnel.

⚠ CAUTION

Remove the COLLECTION CELL and remove and discard the cardboard over the cell.

NOTE: No sheetmetal screws may be used from 0-4" from the bottom of the unit. Screws will interfere with the Air Cleaner. See Figure 4.

REMOVING THE BOTTOM PLATE

- Once the furnace is in place, remove the two screws located at the front bottom corners of the furnace.
- Lean the furnace back slightly and remove the bottom panel.
- Replace the two screws removed in step a.

REMOVING THE COLLECTION CELL AND FIELD CHARGER

When COLLECTION CELLS and FIELD CHARGER must be removed, follow the steps below.

- Remove the lower furnace door.
- Remove the four screws holding the inner blower panel and remove panel. Set aside in a safe place until the unit is set in place and ready to start up.
- Remove the COLLECTION CELL by sliding forward. Remove the cardboard from the COLLECTION CELL and discard. Set aside in a safe place until the unit is set in place and ready to start up.
- Disconnect the Green return wire and the Red high voltage wire. Twist and pull the connector on the Red wire to release.
- Remove the two hold down screws on the bottom of the FIELD CHARGER and retain.
- Remove the Field Charger. Set aside in a safe place until the unit is set in place and ready to start up.
- Set furnace in place. Repeat step a-g in reverse order. Do Not put cardboard back in furnace. Inner blower door MUST be put back into place.

UPFLOW INSTALLATION

Standoffs and screws (See Figure 2) are included with the cased coils for attachment to the Furnace. There are clearance alignment holes near the bottom of the coil wrapper.

Drill screws are used to engage the Furnace top flanges. The standoff is inserted into the cabinet alignment hole. The drill screws are inserted through the standoffs then screwed into the Furnace flange. The coil is always placed downstream of the Furnace airflow. The above instructions apply only if the coil is on top of an upflow Furnace.

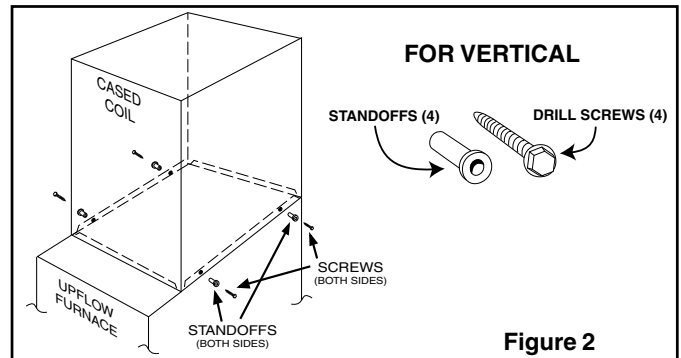

Figure 2

HORIZONTAL INSTALLATION

The coil and Furnace must be fully supported when used in the horizontal position. It is always recommended that an auxiliary drain pan be installed under a horizontally installed evaporator coil or 90% Gas Furnace. Connect the auxiliary drain line to a separate drain line (no trap is needed in this line).

IMPORTANT:

The 2/4TXC cased coil must be placed downstream of the furnace. In horizontal installations, the apex of the coil may point either toward or away from the furnace. See the 2/4TXC coil Installer's Guide for more details.

The cased coil is secured to the Furnace and both the Furnace and the cased coil must be properly supported. The brackets mount using the rear screws on the coil case and use the screws provided to secure the bracket to the Furnace. The remaining bracket is placed as close to center as possible (horizontally) between the coil case front and the upflow Furnace, converted to horizontal, aligns and attaches to the TXC coil. However, the coil requires additional support.

The Furnace may be installed in an attic or crawl space in the horizontal position by placing the Furnace on the left side (as viewed from the front in the vertical position). The horizontal Furnace installation in an attic should be on a service platform large enough to allow for proper clearances on all sides and service access to the front of the Furnace (See Figure 3 & Clearance Table 1). Line contact is only permissible between lines formed by intersections of the top and two sides of the furnace casing and building joists, studs, or framing.

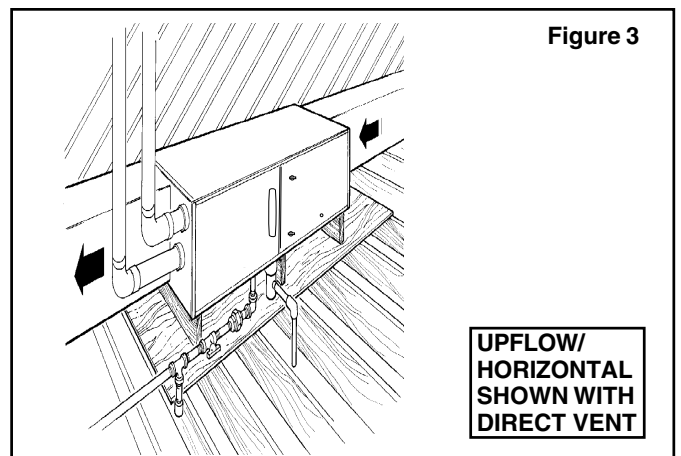

Figure 3

Installer's Guide

The Furnace may be placed horizontally in a crawl space on a pad or other noncombustible material which will raise the unit for sufficient protection from moisture.

The Furnace must be supported at both ends and the middle when installed horizontally. The Furnace must also be elevated approximately 4-6 inches to allow clearance for the condensate drain to exit the cabinet in the horizontal position.

The horizontal Furnace may also be suspended from the joists using all-thread rods with a substantial metal support frame that supports the entire length of the furnace. The rods need to be of sufficient length to allow for proper clearances from combustible materials. The frame needs to be at least 32" in length to allow for access to service panels.

If the Furnace is suspended using steel strap, it must be supported at all four corners and in the middle at the front of the Furnace.

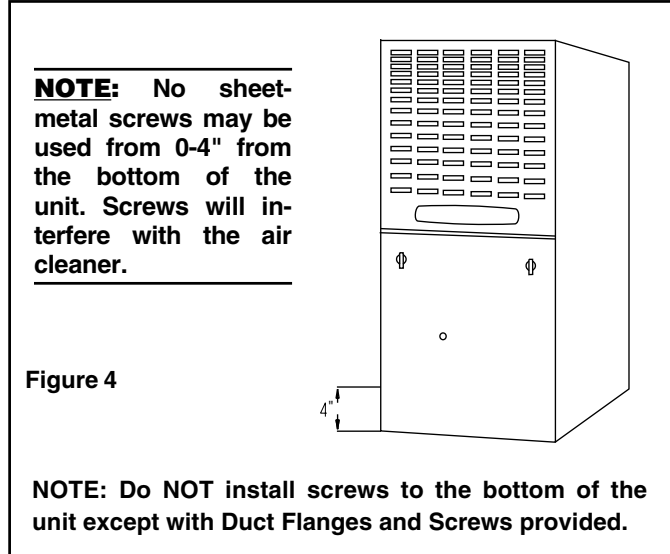

GUIDE FOR THE INSTALLATION OF DUCT FLANGES

⚠ CAUTION

Failure to use pre-drilled holes and the factory provided screws can potentially damage air cleaner components.

Materials

- Duct Flanges
 - Two 23.5" Flanges
 - Two Additional Flanges
 - 15.92" (for 17.5" cabinet)
 - 19.42" (for 21" cabinet)
 - 21.92" (for 24.5" cabinet)
- Screws
 - Eight 5/16" Blunt Tip Screws with 5/16" Hex Head

Steps

1. See Figures 5, 6, and 7 for flange orientation.

2. Attach flanges 1, 2, and 3 (Fig 7) to the unit using the factory provided screws and the pre-drilled holes in the wrapper. Flanges 1 and 2 are the 23.5" flanges that are generic to all units. Flange 3 will be one of two short flanges and the length of which is dependent on the cabinet size.
3. Attach flange 4 (Fig 7) to the duct work (Flanges should be inside duct work). Flange 4 is the remaining short flange.
4. Place duct work with single flange over the flanges that are currently attached to the unit
5. Attach duct work to remaining 3 flanges.
6. Attach the front flange from step 3 to the unit by drilling 1/8" holes into the bottom channel. Use the factory provided 5/16" blunt tip screws to attach.
7. Use field supplied material to make an adequate seal.

DO NOT use silicon based sealant in the airstream.

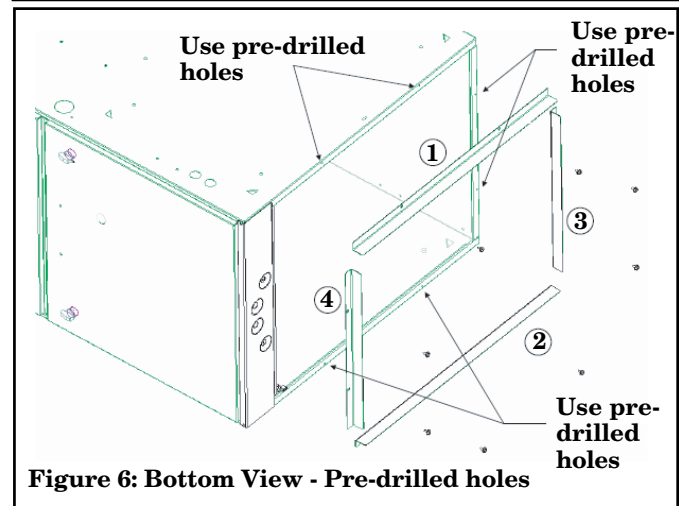
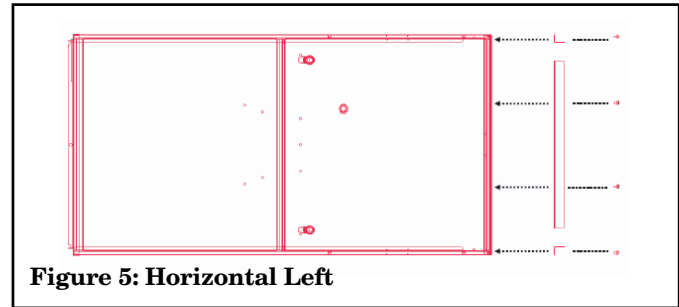

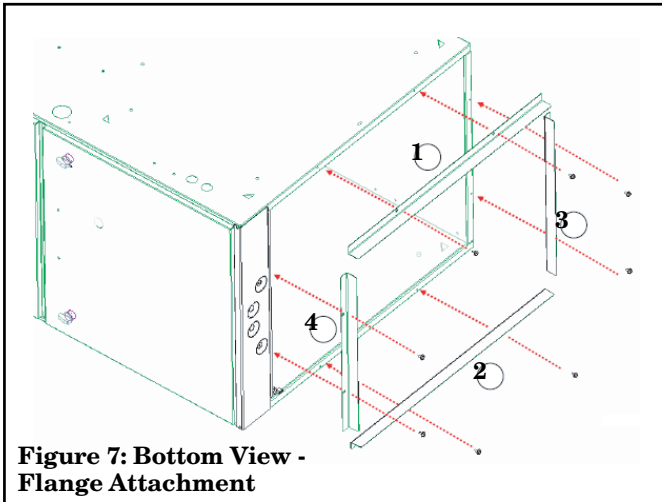

Figure 7: Bottom View - Flange Attachment

Table 1

| Minimum Clearance to Combustible Materials | | | |
|--|--------------------|-------|-------------------|
| Upflow Closet | | | |
| Left Side | 0 inches | Front | 3 inches (note 1) |
| Right Side | 0 inches | Back | 0 inches |
| Flue | 6 inches * | Top | 1 inch |
| Horizontal Closet (see note 2) | | | |
| Top | 2 inches | Back | 3 inches |
| Flue | 6 inches * | Sides | 1 inch |
| Front | 18 inches (note 1) | | |
| Horizontal Alcove (see note 2) | | | |
| Top | 1 inch | Back | 0 inches |
| Flue | 6 inches | Sides | 0 inches |
| Front | 18 inches | | |
| * May be 1" when type B-1 vent is used | | | |
| NOTES: | | | |
| 1) Minimum clearance to front on *UD2D120 is 6 inches | | | |
| 2) May be installed on combustible floor when type B-1 vent is used. | | | |

AIR FOR COMBUSTION AND VENTILATION

Adequate flow of combustion and ventilating air must not be obstructed from reaching the Furnace. Air openings provided in the Furnace casing must be kept free of obstructions which restrict the flow of air. Airflow restrictions affect the efficiency and safe operation of the Furnace. Keep this in mind should you choose to remodel or change the area which contains your Furnace. Furnaces must have a free flow of air for proper performance.

Provisions for combustion and ventilation air shall be made in accordance with "latest edition" of Section 5.3, Air for Combustion and Ventilation, of the National Fuel Gas Code, ANSI Z223.1, or Sections 7.2, 7.3 or 7.4 of CSA B149.1 Installation Codes, and applicable provisions of the local building codes. Special conditions created by mechanical exhausting of air and fireplaces must be considered to avoid unsatisfactory Furnace operation.

Furnace locations may be in "confined space" or "unconfined space". Unconfined space is defined in Table 2 and Figure 8. These spaces may have adequate air by infiltration to provide air for combustion, ventilation, and dilution of flue gases. Buildings with tight construction (for example, weather stripping, heavily insulated, caulked, vapor barrier, etc.), may need additional air provided as described for confined space.

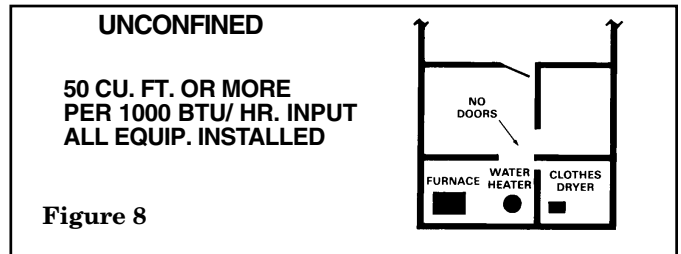

Figure 8

TABLE 2

| MINIMUM AREA IN SQUARE FEET FOR UNCONFINED SPACE INSTALLATIONS | |
|--|--|
| FURNACE MAXIMUM BTUH INPUT RATING | WITH 8 FT. CEILING MINIMUM AREA IN SQUARE FEET OF UNCONFINED SPACE |
| 60,000 | 375 |
| 80,000 | 500 |
| 100,000 | 625 |
| 120,000 | 750 |
| 140,000 | 875 |

1. All air from inside the building as in Figure 10: The confined space shall be provided with two permanent openings communicating directly with an additional room(s) of sufficient volume so that the combined volume of all spaces meets the criteria for an unconfined space. The total input of all gas utilization equipment installed in the combined space shall be considered in making this determination. Refer to Table 3, for minimum open areas required.
2. All air from outdoors as in Figure 11: The confined space shall be provided with two permanent openings, one commencing within 12 inches of the top and one commencing within 12 inches of the bottom of the enclosure.

The openings shall communicate directly, or by ducts, with the outdoors or spaces (crawl or attic) that freely communicate with the outdoors. Refer to Table 3, for minimum open areas required.

Installer's Guide

CONFINED

**LESS THAN 50 CU. FT.
PER 1000 BTU/ HR. INPUT
ALL EQUIP INSTALLED**

Figure 9



**TABLE 3
MINIMUM FREE AREA IN SQUARE INCHES
EACH OPENING (FURNACE ONLY)**

| Furnace Maximum BTUH/INPUT Rating | Air From Inside | Air From Outside | |
|--|-----------------------|------------------|--------------------|
| | | Vertical Duct | Horizontal Duct |
| 60,000 | 100 | 15 | 30 |
| 80,000 | 100 | 20 | 40 |
| 100,000 | 100 | 25 | 50 |
| 120,000 | 120 | 30 | 60 |
| 140,000 | 140 | 35 | 70 |

Confined spaces are installations with less than 50 cu. ft. of space per 1000 BTU/ hr input from all equipment installed. Confined space is defined in Figure 9. Air for combustion and ventilation requirements can be supplied from inside the building as in Figure 10 or from the outdoors, as in Figure 11.

3. The following types of installations will **require** use of OUTDOOR AIR for combustion, due to chemical exposures:

- * Commercial buildings
- * Buildings with indoor pools
- * Furnaces installed in commercial laundry rooms
- * Furnaces installed in hobby or craft rooms
- * Furnaces installed near chemical storage areas.

Exposure to the following substances in the combustion air supply will also require OUTDOOR AIR for combustion:

- * Permanent wave solutions
- * Chlorinated waxes and cleaners
- * Chlorine based swimming pool chemicals
- * Water softening chemicals
- * Deicing salts or chemicals
- * Carbon Tetrachloride
- * Halogen type refrigerants
- * Cleaning solvents (such as perchloroethylene)
- * Printing inks, paint removers, varnish, etc.
- * Hydrochloric acid
- * Cements and glues
- * Antistatic fabric softeners for clothes dryers
- * Masonry acid washing materials

NOTE: Extended warranties are not available in some instances. Extended warranty does not cover repairs to equipment installed in establishments with corrosive atmospheres, including but limited to, dry cleaners, beauty shops, and printing facilities.

DUCT CONNECTIONS

Air duct systems should be installed in accordance with standards for air conditioning systems, National Fire Protection Association Pamphlet No. 90. They should be sized in accordance with ACCA Manual D or whichever is applicable.

Central Furnaces, when used in connection with cooling units, shall be installed in parallel or on the upstream side of the cooling coil to avoid condensation in the heat exchanger. With a parallel flow arrangement, the dampers or other means used to control flow of air shall be adequate to prevent chilled air from entering the Furnace, and if manually operated, must be equipped with means to prevent operation of either unit unless the damper is in full heat or cool position.

On any job, flexible connections of nonflammable material may be used for return air and discharge connections to prevent transmission of vibration. Though these units have been specifically designed for quiet, vibration free operation, air ducts can act as sounding boards and could, if poorly installed, result in vibration to the annoyance level.

When the Furnace is located in a utility room adjacent to the living area, the system should be carefully designed with returns to minimize noise transmission through the return air grille. Although these Furnaces are designed with large blowers operating at moderate speeds, any blower moving a high volume of air will produce audible noise which could be objectionable when the unit is located very close to a living area. It is often advisable to route the return air ducts under the floor or through the attic. Such design permits the installation of air return remote from the living area (i.e. central hall).

When the Furnace is installed so that the supply ducts carry air circulated by the Furnace to areas outside the space containing the Furnace, the return air shall also be handled by a duct(s) sealed to the Furnace and terminating outside the space containing the Furnace.

Where there is no complete return duct system, the return connection must be run full size from the Furnace to a location outside the utility room, basement, attic, or crawl space.

Do NOT install return air through the back of the Furnace cabinet.

Bottom Return Only

NOTE: Minimum return air temperature is 55° F.

NOTE: No sheetmetal screws may be used from 0-4" from the bottom of the unit. Screws will interfere with the air cleaner. See Figure 4.

Figure 10

CONFINED SPACE
AIR FROM INSIDE BUILDING

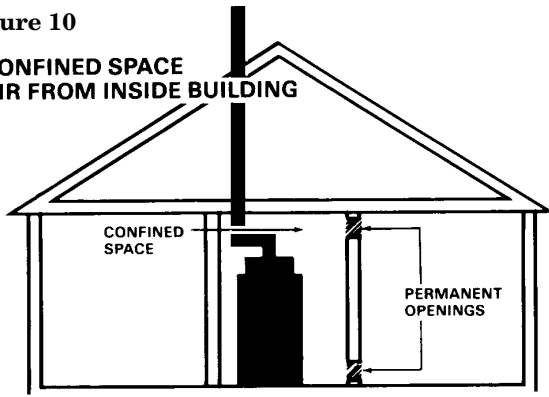
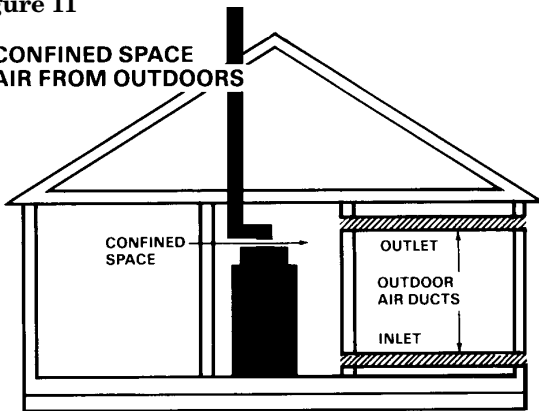
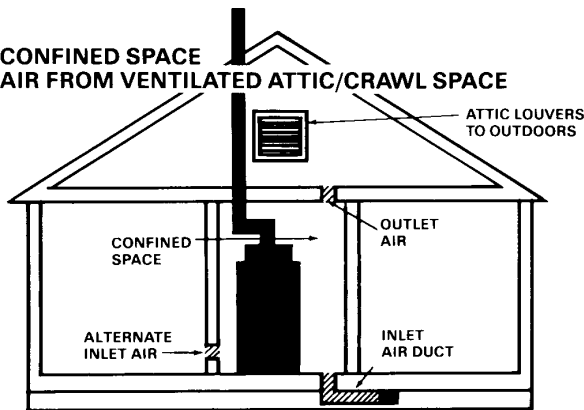

Figure 11

CONFINED SPACE
AIR FROM OUTDOORS



CONFINED SPACE
AIR FROM VENTILATED ATTIC/CRAWL SPACE



CONFINED SPACE
AIR FROM VENTILATED ATTIC

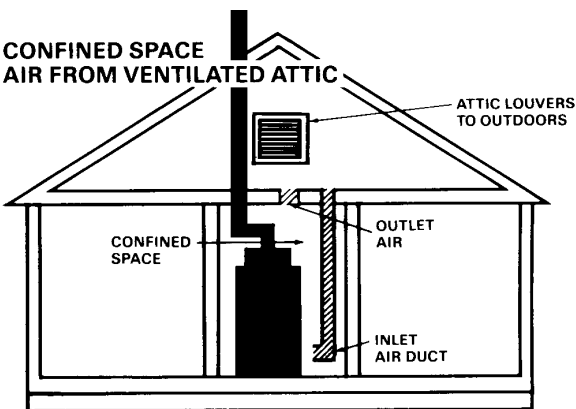

The following warning complies with State of California law, Proposition 65.

⚠ WARNING

Hazardous Gases!

Exposure to fuel substances or by-products of incomplete fuel combustion is believed by the state of California to cause cancer, birth defects, or other reproductive harm.

Carbon monoxide, fire or smoke can cause serious bodily injury, death, and/ or property damage.

A variety of potential sources of carbon monoxide can be found in a building or dwelling such as gas-fired clothes dryers, gas cooking stoves, water heaters, Furnaces and fireplaces. The U.S. Consumer Product Safety Commission recommends that users of gas-burning appliances install carbon monoxide detectors as well as fire and smoke detectors per the manufacturers installation instructions to help alert dwelling occupants of the presence of fire, smoke or unsafe levels of carbon monoxide. These devices should be listed by Underwriters Laboratories, Inc. *Standards for Single and Multiple Station Carbon Monoxide Alarms, UL 2034* or CSA International Standard, *Residential Carbon Monoxide Alarming Devices, CSA 6.19*

NOTE: The manufacturer of your Furnace does NOT test any detectors and makes no representations regarding any brand or type of detector.

Connect duct work to Furnace. See Outline Drawing for supply and return duct size and location. Flexible duct connectors are recommended to connect both supply and return air ducts to the Furnace. If only the front of the Furnace is accessible, it is recommended that both supply and return air plenums are removable.

GENERAL VENTING

THIS FURNACE EXHAUST MUST BE VENTED TO THE OUTDOORS. THESE FURNACES ARE INDUCED DRAFT VENTED AND MUST NOT BE CONNECTED TO ANY VENT SERVING ANOTHER APPLIANCE. PLEASE NOTE THAT THESE FURNACES USE POSITIVE-PRESSURE VENT SYSTEMS.

Proper venting is essential to obtain maximum efficiency from a condensing Furnace. Proper installation of the vent system is necessary to assure drainage of the condensate and prevent deterioration of the vent system.

American Gas Association has certified the design of condensing Furnaces for a minimum of 0" clearance from combustible materials with a single wall plastic vent pipe.

Installer's Guide

The recommended system is assembled from 2", 2-1/2", or 3" plastic pipe and fittings (See Table 4, page 12). Where the system is routed to the outdoors through an existing masonry chimney containing flue products from another gas appliance, or where required by local codes, then 3" venting of Type 29-4C stainless steel must be used in place of PVC material.

These Furnaces have been classified as CATEGORY IV Furnaces in accordance with ANSI Z21.47 "latest edition" standards. Category IV Furnaces operate with positive vent pressure and with a vent gas temperature less than 140°F above the dewpoint. These conditions require special venting systems, which must be gas tight and water tight.

NOTE: When an existing Furnace is removed from a venting system serving other gas appliances, the venting system is likely to be too large to properly vent the remaining attached appliances.

The following steps shall be followed with each appliance remaining connected to the common venting system placed in operation, while the other appliances remaining connected to the common venting system are not in operation.

1. Seal any unused openings in the common venting system.
2. Visually inspect the venting system for proper size and horizontal pitch and determine there is no blockage or restriction, leakage, corrosion or other deficiencies which could cause an unsafe condition.
3. In so far as is practical, close all building doors and windows and all doors between the space in which the appliances remaining connected to the common venting system are located and other spaces of the building. Turn on clothes dryers and any appliances not connected to the common venting system. Turn on any exhaust fans, such as range hoods and bathroom exhausts, so they will operate at maximum speed. Do not operate a summer exhaust fan, close fireplace dampers.
4. Follow the lighting instructions. Place the appliance being inspected in operation. Adjust Comfort Control so appliance will operate continuously.
5. After it has been determined that each appliance remaining connected to the common venting system properly vents when tested as outlined above, return door, windows, exhaust fans, fireplace dampers and any other gas-burning appliance to their previous conditions of use.

If improper venting is observed during any of the above tests, the remaining common venting system must be corrected. Correction could require rerouting or resizing the remaining vent system.

IMPORTANT:

*These Furnaces may be installed as Direct Vent (sealed combustion) or as Nondirect Vent (single pipe). The Furnaces are shipped **DIRECT VENT** with sealed combustion.*

For **DIRECT VENT APPLICATION:** The Furnaces must be vented to the exterior of the house and combustion air **MUST** come through the inlet air pipe **FROM OUTSIDE AIR.**

NOTE: BAYVENT200* accessories can be used for inlet and outlet terminals when the pipes do not exit the structure together.

For **NON-DIRECT VENT APPLICATION:** The Furnace shall be vented to the exterior of the house, but combustion air may enter from the surrounding area as long as combustion air requirements are met. (See AIR FOR COMBUSTION AND VENTILATION)

FURNACE VENT/ INLET PIPE INSTALLATION

There are many different variations of the vent/ inlet air pipe combination. The vent/ inlet air combination used for installation of these Furnaces depends on the needs of the location. However, these guidelines must be followed:

1. The Furnace must vent outside the structure.
2. Furnace combustion air requirements must be met for non-direct, single pipe applications.
3. For direct vent application of these Furnaces, the vent pipe and air inlet pipe do not have to exit in the same air space or even on the same surface of the structure. *However, the longest individual pipe will decide the value for the longest allowable equivalent vent/ inlet air length as shown in the vent length table on page 14.*

The following are **EXAMPLES ONLY:**

EX. 1 —

Example 1 shows that the vent may go vertical while the inlet air may be on any side of the structure. The vent pipe would decide the maximum equivalent length for the pipe depending on the furnace and pipe size.

VENT FITTING MATERIAL – PLASTIC

Gas and liquid tight single wall vent fittings, designed for resistance to corrosive flue condensate, **MUST** be used throughout.

Listed in Table 4 are 2" and 3" size fittings that meet these requirements. The materials listed are various grades of PVC and ABS plastic.

PIPE JOINTS: All joints must be fastened and sealed to prevent escape of combustion products into the building.

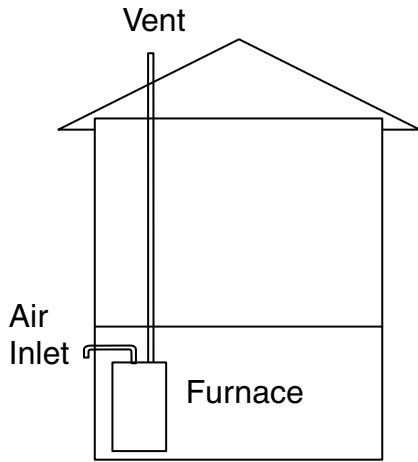

EX. 2 —

Example 2 shows the vent pipe exhausting through the roof and the inlet air coming from the interior of the house (See Note 1). The inlet air coming from the interior of the house must meet combustion requirements for area, etc., as shown in the section AIR FOR COMBUSTION AND VENTILATION in this Installer's Guide.

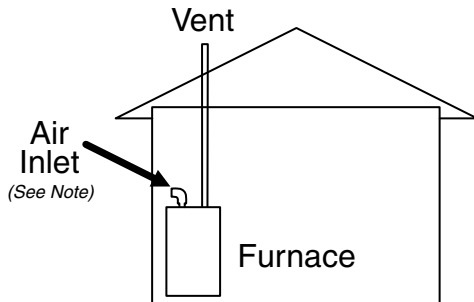

EX. 3 —

Example 3 shows the vent exiting one side of the house while the inlet air is on the opposite side of the structure. Here the vent pipe length must be within the allowable length for the size of Furnace and size of the vent pipe. This example demonstrates that the pipes do not have to exit on the same side of the structure.

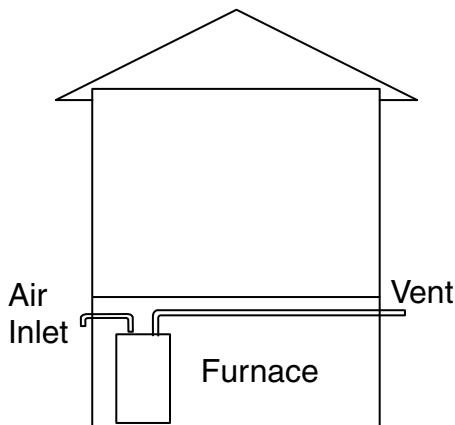

EX. 4 —

The inlet air does not have to come from outside the structure. Example 4 shows the inlet air (See Note 1), may come from the attic if the requirements for combustion air are met as shown in the section AIR FOR COMBUSTION AND VENTILATION.

NOTE: If only the flue gas pipe is to the outside of the structure, a straight section of pipe (long enough to exit the Furnace cabinet) must be attached to the inlet air side with an elbow (which is 5 to 10 equiv. ft.) installed on the end to prevent dust and debris from falling directly into the Furnace.

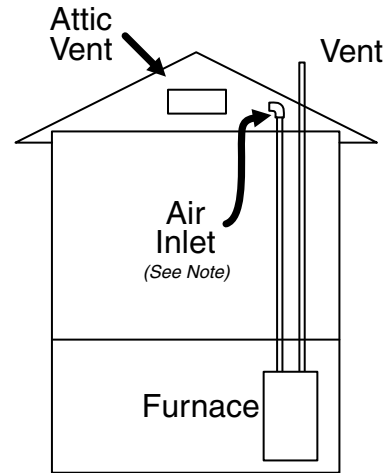

NOTE: It is recommended that the first joints from the Furnace be connected and sealed with high temperature RTV. This will enable the pipes to be removed later without cutting.

Be sure to properly support these joints.

BONDING OF PVC

Commercially available solvent cement for PVC must be used to join PVC pipe fittings. Follow instructions on container carefully.

Pipe and Fitting – ASTM D1785, D2466, D2661, & D2665

PVC Primer and Solvent Cement – ASTM D2564

Procedure for Cementing Joints – Ref ASTM D2855

1. Cut pipe square, remove ragged edges and burrs. Chamfer end of pipe, then clean fitting socket and pipe joint area of all dirt, grease, moisture or chips.
2. After checking pipe and socket for proper fit, wipe socket and pipe with cleaner-primer. Apply a liberal coat of primer to inside surface of socket and outside of pipe.

DO NOT ALLOW PRIMER TO DRY BEFORE APPLYING CEMENT.

3. Apply a thin coat of cement evenly in the socket. Quickly apply a heavy coat of cement to the pipe end and insert pipe into fitting with a slight twisting movement until it bottoms out.

Installer's Guide

4. Hold the pipe in the fitting for 30 seconds to prevent tapered socket from pushing the pipe out of the fitting.
5. Wipe all excess cement from the joint with a rag. Allow 15 minutes before handling. Cure time varies according to fit, temperature and humidity.

NOTE: Follow venting instructions carefully when using PVC cement.

IMPORTANT:

All joints must be water tight. Flue condensate is somewhat acidic, and leaks can cause equipment damage.

Connection of the pipe and collar of the combustion air inlet should just be a friction fit. It is recommended that the inlet air joint be sealed with RTV type sealant to allow the joint to be separated for possible future service. The inlet and vent pipes must be properly supported throughout the entire length. See Figure 12.

NOTE: Vent termination kit BAYAIR30AVENTA or BAYVENT200B may be used in addition to the horizontal and vertical termination options shown in the following figures.

A variety of potential sources of carbon monoxide can be found in a building or dwelling such as gas-fired clothes dryers, gas cooking stoves, water heaters, furnaces and fireplaces. The U.S. Consumer Product Safety Commission recommends that users of gas-burning appliances install carbon monoxide detectors as well as fire and smoke detectors, listed by a nationally recognized agency (e.g. Underwriters Laboratories or International Approval Services), to help alert dwelling occupants of the presence of fire, smoke or unsafe levels of carbon monoxide.

NOTE: The manufacturer of your furnace does not test any detectors and makes no representations regarding any brand or type of detector.

TABLE 4

| PVC VENT FITTING MATERIAL These fittings are available from your Gas Furnace Distributors. | | | |
|---|--------------------------|--|------------|
| <p>WALL MOUNT FLANGE BAY69X148</p> | | <p>WALL MOUNT FLANGE BAY69X147</p> | |
| PLASTIC PIPE DESIGNATIONS | | | |
| PVC | | | |
| ASTM STANDARD | PIPE TYPE | ALLOWABLE TEMPERATURE | MARKING |
| F891 | CELLULAR CORE | *158 | ASTM F891 |
| D2665 | DWV PIPE | **158 | ASTM D2665 |
| D1785 | SCH 40, 80, 120 | **158 | ASTM D1785 |
| D2241 | SDR SERIES | **158 | ASTM D2241 |
| CPVC | | | |
| ASTM STANDARD | PIPE TYPE | ALLOWABLE TEMPERATURE | MARKING |
| D2846 | CPVC 41 | **212 | ASTM D2846 |
| F441 | SCH 40, 80 | **212 | ASTM F441 |
| F442 | SDR SERIES | **212 | ASTM F442 |
| ABS | | | |
| ASTM STANDARD | PIPE TYPE | ALLOWABLE TEMPERATURE | MARKING |
| D2661 | SCH 40 DWV | ***180 | ASTM D2661 |
| F628 | SCH 40 DWV CELLULAR CORE | ***180 | ASTM F628 |
| * - Allowable temperatures based on classifications covered in ASTM D4396 [Deflection Temps Under Load (264 PSI)] | | | |
| ** - Allowable temperatures based on classifications covered in ASTM D1784 [Deflection Temps Under Load (264 PSI)] | | | |
| *** - Allowable temperatures based on classifications covered in ASTM D3965 [Deflection Temps Under Load (264 PSI)] | | | |

IMPORTANT:

Products installed in Canada must use vent systems that are certified to the Standard for Type BH Gas Venting Systems (ULC S636) for Class II-A venting systems (up to 65°C). Components of the vent system must not be interchanged with other vent systems or unlisted pipe or fittings. Plastic components, specified primers, and glues must be from a single system manufacturer and not intermixed with other system manufacturer's vent system parts. In addition, the first three feet of the vent pipe must be visible for inspection.

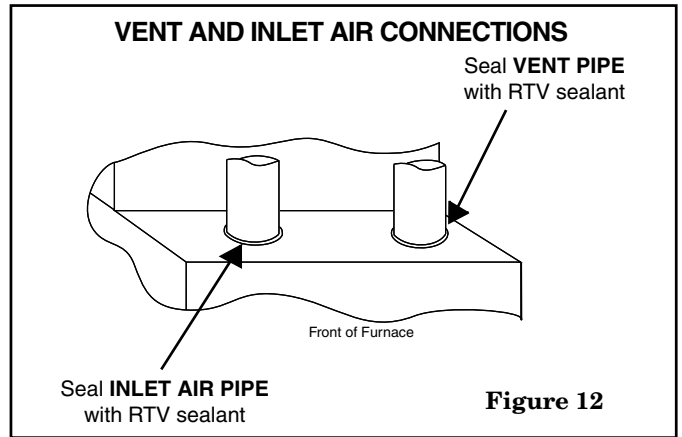

TABLE 5

| VENT LENGTH TABLE | | | |
|--------------------------|---|----------------------|--------------------|
| ALTITUDE | MAXIMUM TOTAL EQUIVALENT LENGTH IN FEET FOR VENT AND INLET AIR (SEE NOTES) | | |
| 0-7,000 Feet | 2 INCH PIPE | 2.5 INCH PIPE | 3 INCH PIPE |
| UX2B060AFV3VA | 200 | 200 | 200 |
| UX2B080AFV3VA | 50 | 120 | 200 |
| UX2C100AFV4VA | Not Allowed | 60 | 200 |
| UX2D120AFV5VA | Not Allowed | Not Allowed | 200 |
| 7,000-9,500 Feet | 2 INCH PIPE | 2.5 INCH PIPE | 3 INCH PIPE |
| UX2B060AFV3VA | 100 | 100 | 100 |
| UX2B080AFV3VA | 25 | 60 | 100 |
| UX2C100AFV4VA | Not Allowed | 30 | 100 |
| UX2D120AFV5VA | Not Allowed | Not Allowed | 100 |
| 9,500-12,000 Feet | 2 INCH PIPE | 2.5 INCH PIPE | 3 INCH PIPE |
| UX2B060AFV3VA | 50 | 50 | 50 |
| UX2B080AFV3VA | Not Allowed | 30 | 50 |
| UX2C100AFV4VA | Not Allowed | Not Allowed | 50 |
| UX2D120AFV5VA | Not Allowed | Not Allowed | 50 |

NOTES: * - First letter may be "A" or "T"

1. Minimum vent length for all models: 3' horizontal or 3' vertical.
2. DO NOT MIX PIPE DIAMETERS IN THE SAME LENGTH OF PIPE OUTSIDE THE FURNACE CABINET (Except adapters at the top of the furnace). If different inlet and vent pipe sizes are used, the vent pipe must adhere to the maximum length limit shown in the table above (See note 6 below for exception). The inlet pipe can be of a larger diameter, but never smaller than the vent pipe.
3. MAXIMUM PIPE LENGTHS MUST NOT BE EXCEEDED! THE LENGTH SHOWN IS NOT A COMBINED TOTAL, IT IS THE MAXIMUM LENGTH OF EACH (Vent or Inlet air pipes).
4. One SHORT radius 90° elbow is equivalent to 10' of 3" pipe and one LONG radius elbow is equivalent to 6' of 3" pipe. One 90° elbow is equivalent to 7½' of 2½" pipe or 5' of 2" pipe. Two 45° elbows equal one 90° elbow.
5. The termination tee or bend must be included in the total number of elbows. If the BAYAIR30AVENTA termination kit is used, the equivalent length of pipe is 5 feet. BAYVENT200B equivalent length is 0 feet.
6. Pipe adapters are field supplied (except 120).

Installer's Guide

HORIZONTAL INSTALLATION (Upflow/ Horizontal)

NOTE: When the factory supplied 2X3" offset reducing coupling is used for 3" vent pipe installation, make sure the marking "TOP" is located on the top side of the pipe.

The straight side of the coupling must be on bottom for proper drainage of condensate. See Figure 13.

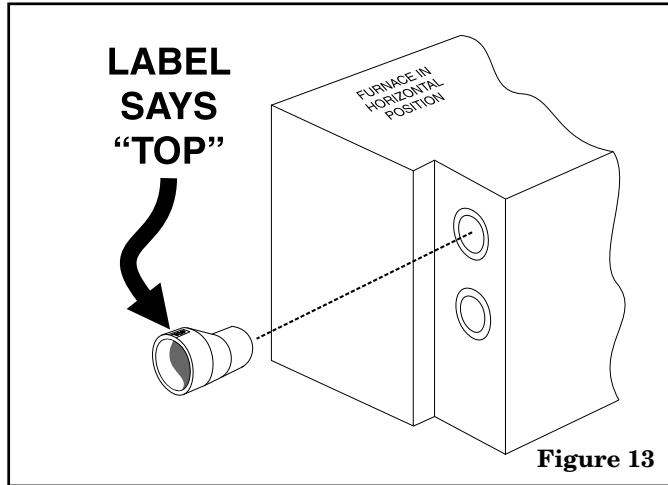

⚠ CAUTION

When the vent pipe is exposed to temperatures below freezing, i.e., when it passes through unheated spaces, etc., the pipe must be insulated with 1/2 inch (22.7 mm) thick Armaflex-type insulation or equal.

If the space is heated sufficiently to prevent freezing, then the insulation would not be required. If domestic water pipes are not protected from freezing then it is assumed the space meets the condition of a heated space.

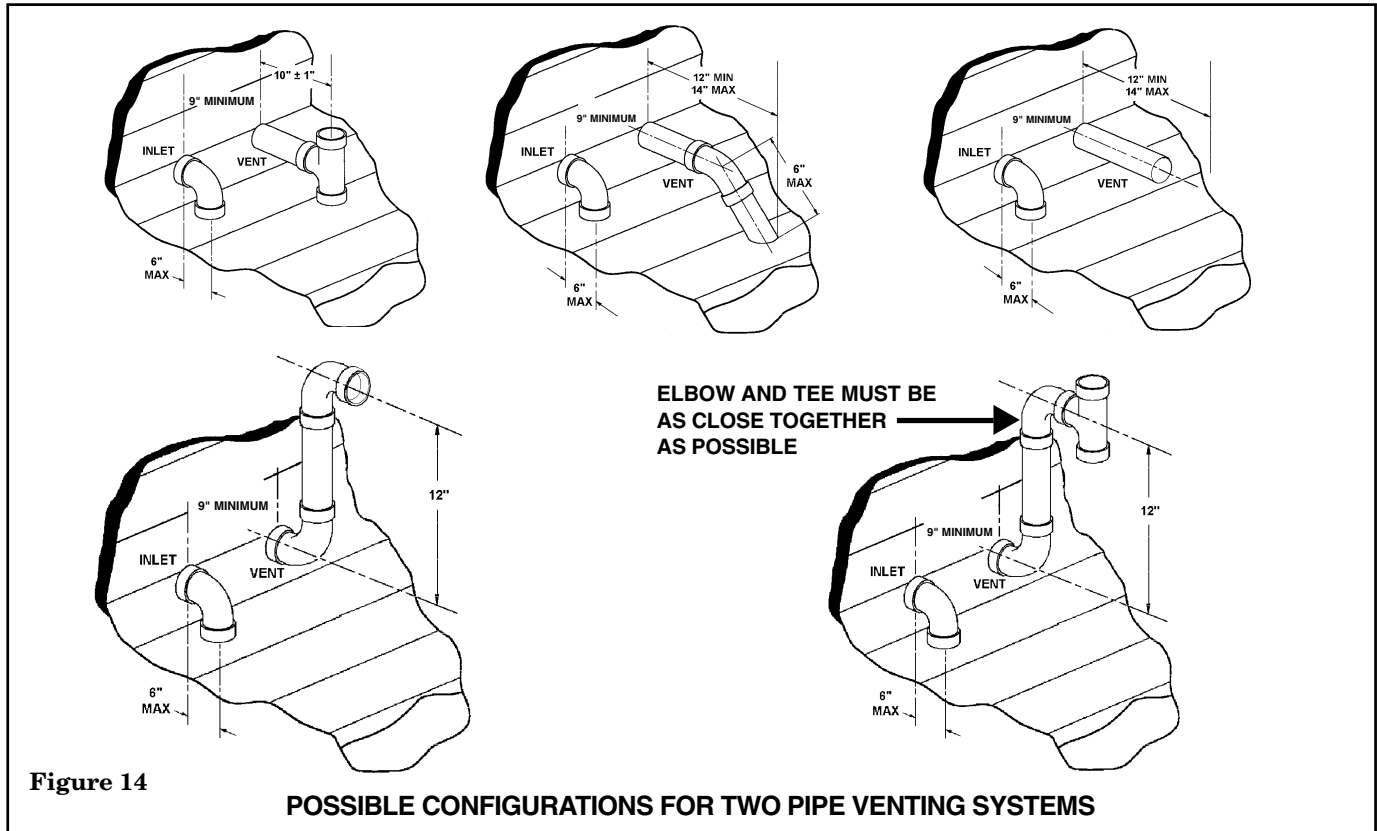
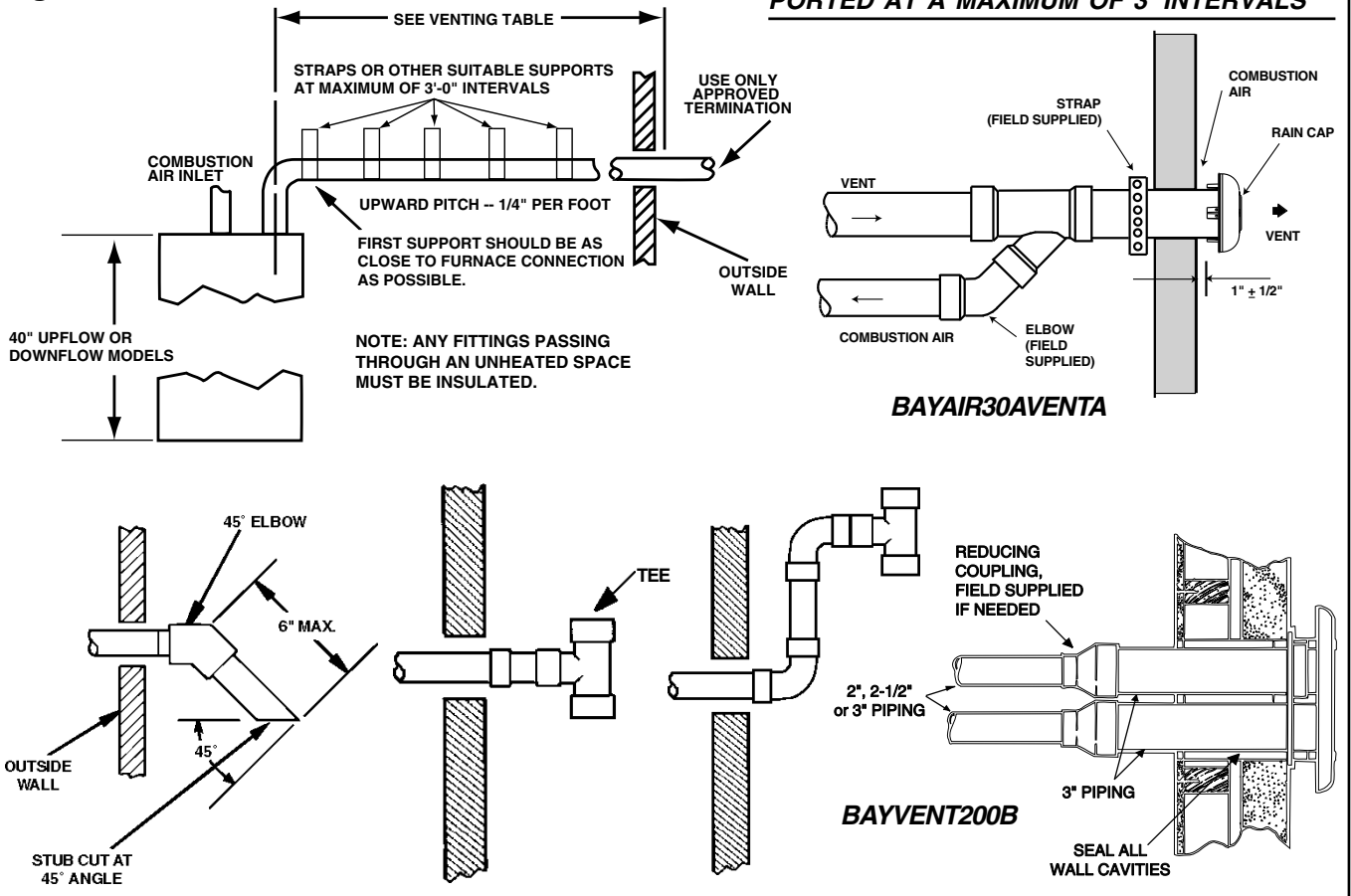

Figure 15



NOTE: VENT AND INLET MUST BE SUPPORTED AT A MAXIMUM OF 3' INTERVALS

HORIZONTAL VENTING THROUGH WALL

These Furnaces may be installed as direct vent (as shipped) or as nondirect vent. Installation must conform to national, state, and local codes.

The vent & inlet terminals must be located at least 12" minimum above normally expected snow accumulation level.

Avoid areas where staining or condensate drippage may be a problem.

Location of the vent/ wind terminal should be chosen to meet the requirements of Figure 16 for either direct or non-direct vent applications.

PITCH — Venting through the wall must maintain 1/4" per foot pitched upward to insure that condensate drains back to the Furnace.

FLUE GAS DEGRADATION — The moisture content of the flue gas may have a detrimental effect on some building materials. This can be avoided by using the roof or chimney venting option. When wall venting is used on any surface that can be affected by this moisture, it is recommended that a corrosion resistant shield (24 inches square) be used behind the vent terminal. This shield can be wood, plastic, sheet metal, etc. Also, silicone caulk all cracks, seams and joints within 3 feet of the vent terminal.

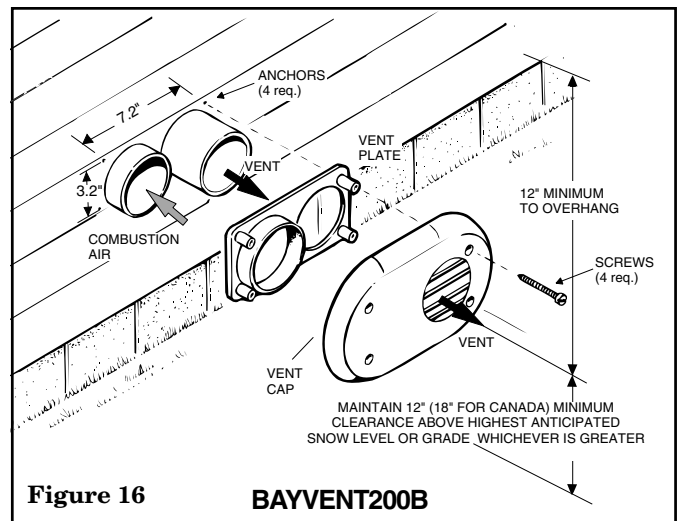
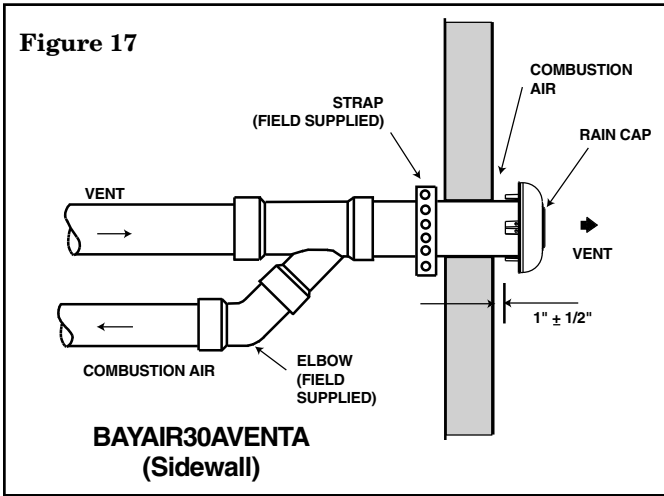

Figure 16

BAYVENT200B

Installer's Guide

Figure 17



COMBUSTIBLE MATERIAL WALL

A minimum clearance of 1" to combustible materials must be maintained when using single wall stainless steel venting. See Figure 18.

Shield material to be a minimum of 24 gauge stainless or aluminized sheet metal. Minimum dimensions are 12"x12". Shield must be fastened to both inside and outside of wall. Use screws or anchor type fasteners suited to the outside or inside wall surfaces.

NONCOMBUSTIBLE MATERIAL WALL

The hole through the wall must be large enough to maintain pitch of vent and properly seal. Use cement mortar seal on inside and outside of wall. See Figure 19.

Figure 18

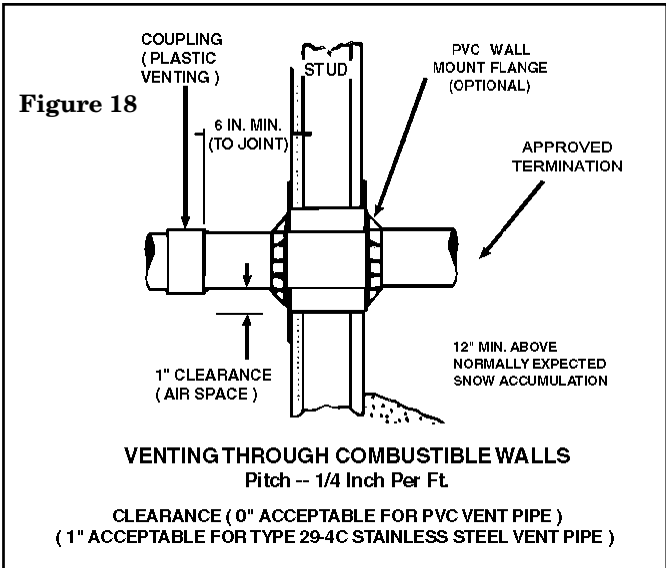

Figure 19

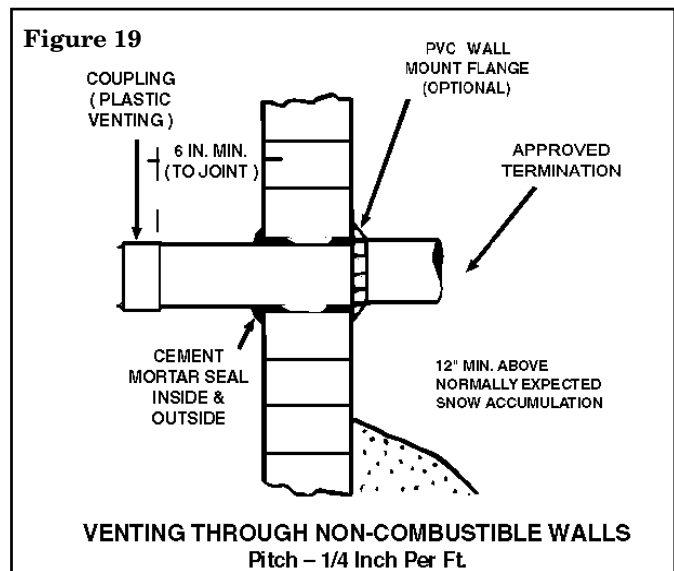

Figure 20

SUPPORT HORIZONTAL PIPE EVERY 3' 0" WITH THE FIRST SUPPORT AS CLOSE TO THE FURNACE AS POSSIBLE. INDUCED DRAFT BLOWER, HOUSING, AND FURNACE MUST NOT SUPPORT THE WEIGHT OF THE FLUE PIPE.

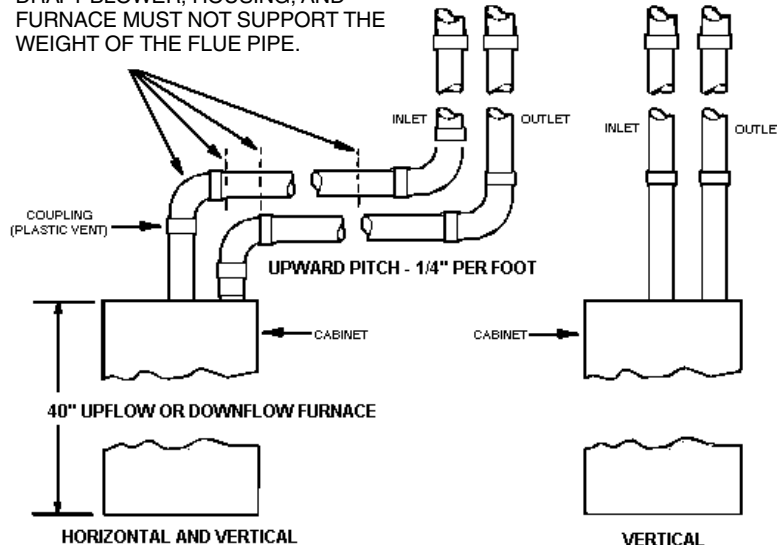

Figure 21

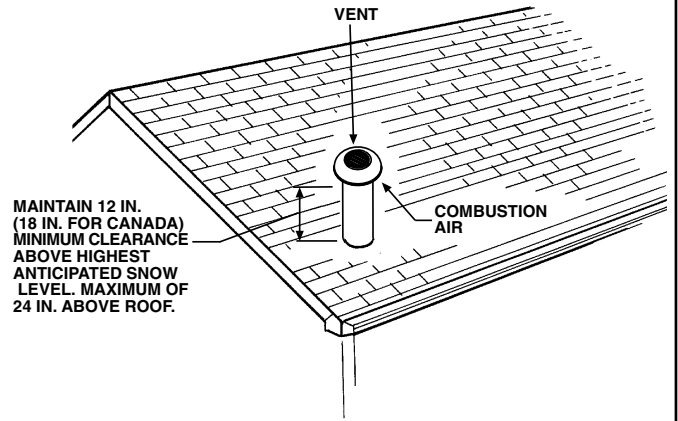
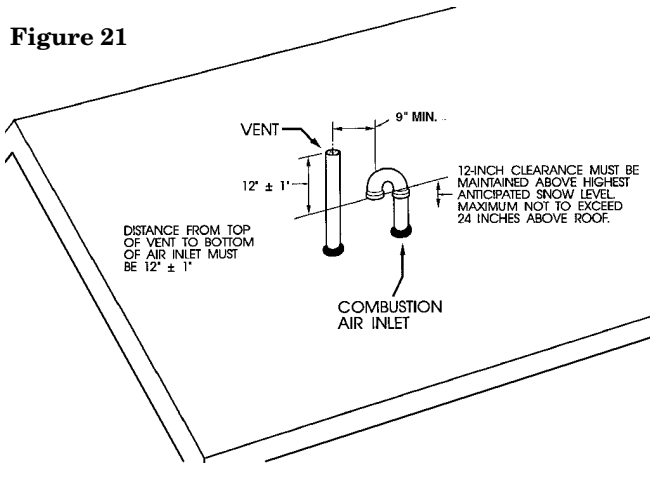
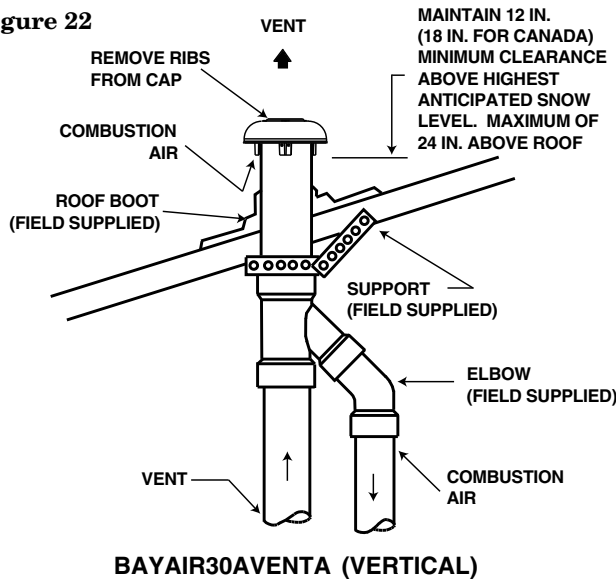

Figure 22



VENTING THROUGH THE ROOF

When penetrating roof with a 2" PVC vent pipe, a 2" electrical conduit flashing may be used for a weather tight seal. Lubricate flexible seal on flashing before PVC pipe is pushed through the seal. (Field Supplied)

NOTE: No vent cap as shown in Figure 21 is the preferred method for vertical vent termination in extremely cold climates.

In extreme climate conditions, insulate the exposed pipe above the roof line with Armaflex type insulation.

VENT FITTING MATERIAL – STAINLESS STEEL

Gas and liquid tight single wall metal vent fitting, designed for resistance to corrosive flue condensate such as Type 29-4C MUST be used throughout.

These fittings and fitting accessories are to be field supplied.

DIRECTION OF STAINLESS STEEL FITTING

All stainless steel fitting must be installed with male end towards the Furnace.

All horizontal stainless steel sections must be positioned with the seam on top.

All long horizontal sections must be supported to prevent sagging.

All pipe joints must be fastened and sealed to prevent escape of combustion products into the building.

Figure 23

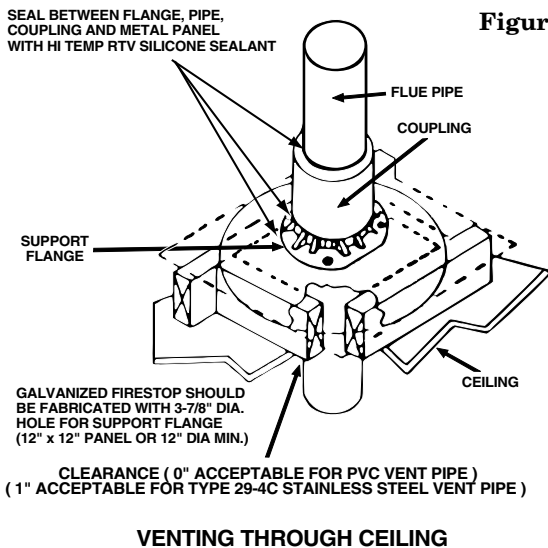

Installer's Guide

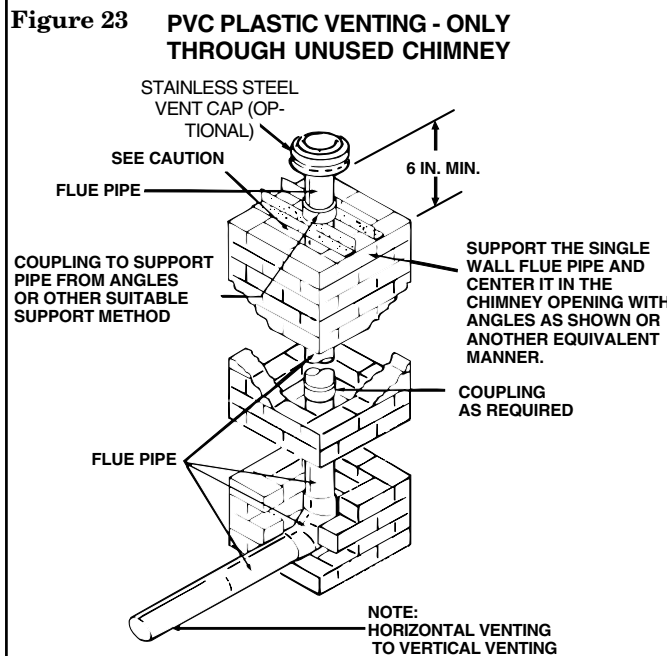
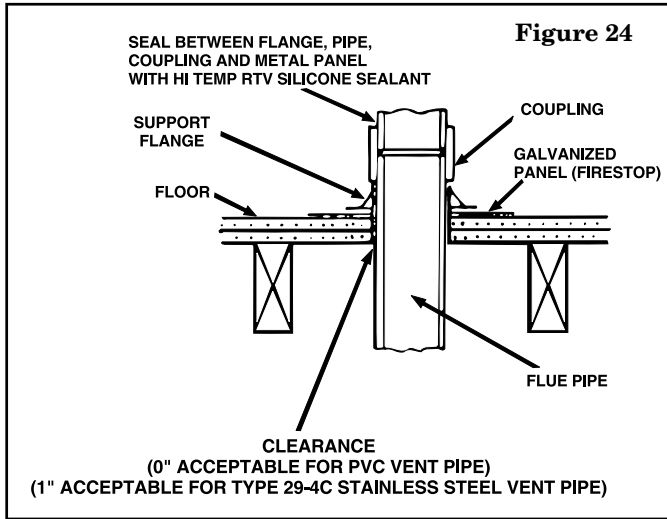

⚠ CAUTION

Do NOT run vent through chimney for wood burning or oil Furnaces or incinerators or any other gas appliance.

IMPORTANT –
The single wall flue pipe joints must be sealed. The 90° elbow connection to vertical pipe must be sealed to prevent condensate leakage to base of masonry chimney.

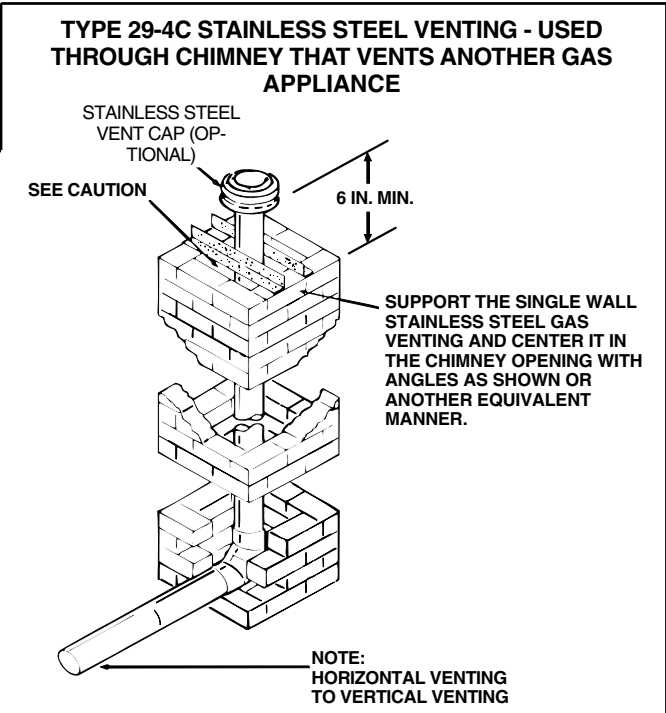

⚠ CAUTION

Do NOT run vent through chimney for wood burning or oil Furnaces or incinerators. If remaining free area between single wall flue pipe and masonry chimney is to be used for another gas appliance venting area must be sufficient to vent that appliance and that appliance must be connected to chimney with separate entry openings.

IMPORTANT –
The single wall flue pipe joints must be sealed. The 90° elbow connection to vertical pipe must be sealed to prevent condensate leakage to base of masonry chimney.

VENTING ROUTED THROUGH A MASONRY CHIMNEY

Figure 25

HORIZONTAL VENT CLEARANCES

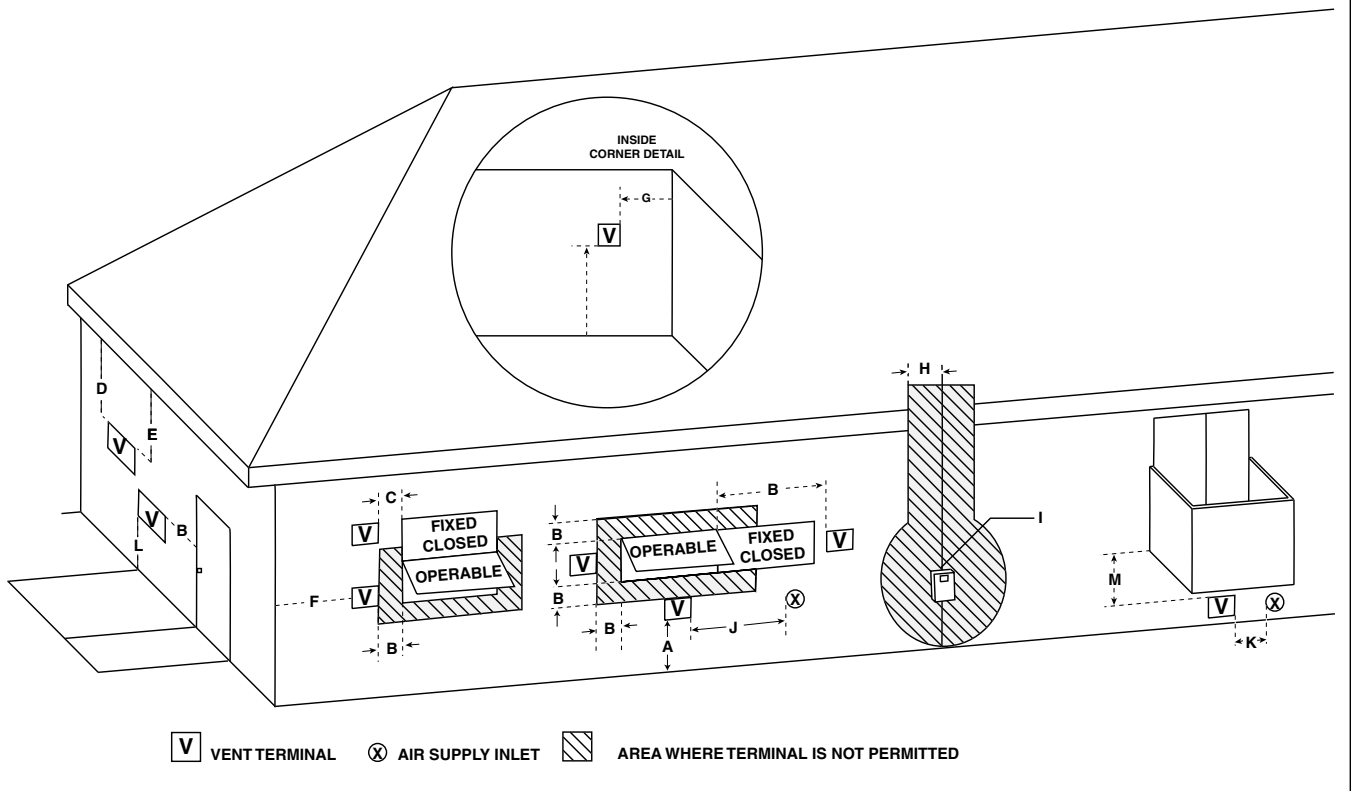

| Non-Direct Vent Terminal Clearances | | | |
|-------------------------------------|--|---|--|
| | | Canadian Installations | US Installations |
| A= | Clearance above grade, veranda, porch, deck, or balcony | 12 inches (30 cm) | 12 inches (30 cm) |
| B= | Clearance to window or door that may be opened | 6 inches (15 cm) for appliances \leq 10,000 Btuh (3 kw), 12 inches (30 cm) for appliances $>$ 10,000 Btuh (3 kw) and \leq 100,000 Btuh (30 kw), 36 inches (91 cm) for appliances $>$ 100,000 Btuh (30 kw) | 4 feet (1.2m) below or to the side of opening; 1 foot (0.3m) above opening. |
| C= | Clearance to permanently closed window | * | * |
| D= | Vertical clearance to ventilated soffit located above the terminal within a horizontal distance of 2 feet (61 cm) from the center line of the terminal | * | * |
| E= | Clearance to unventilated soffit | * | * |
| F= | Clearance to outside corner | * | * |
| G= | Clearance to inside corner | * | * |
| H= | Clearance to each side of center line extended above meter/regulator assembly | 3 feet (91 cm) with a height 15 feet (4.5 m) above the meter/regulator assembly | * |
| I= | Clearance to service regulator vent outlet | 3 feet (91 cm) | * |
| J= | Clearance to nonmechanical air supply inlet to building or the combustion air inlet to any other appliance | 6 inches (15 cm) for appliances \leq 10,000 Btuh (3 kw), 12 inches (30 cm) for appliances $>$ 10,000 Btuh (3 kw) and \leq 100,000 Btuh (30 kw), 36 inches (91 cm) for appliances $>$ 100,000 Btuh (30 kw) | 4 feet (1.2 m) below or to side of opening; 1 foot (300 m) above opening |
| K= | Clearance to a mechanical air supply inlet | 6 feet (1.83m) | 3 feet (91 cm) above if within 10 feet (3m) horizontally |
| L= | Clearance above a paved sidewalk or paved driveway located on public property | 7 feet (2.13 m) † | 7 feet (2.13 m) |
| M= | Clearance under veranda, porch, deck, or balcony | 12 inches (30 cm) ‡ | * |

Notes:

- In accordance with the current CSA B149.1 Natural Gas and Propane Installation Code.
- In accordance with the current ANSI Z223.1/NFPA 54 National Fuel Gas Code.
- † A vent shall not terminate directly above a sidewalk or paved driveway that is located between two single family dwelling and serves both dwellings.
- ‡ Permitted only if veranda, porch, deck, or balcony is fully open on a minimum of two sides beneath the floor.
- * Clearance in accordance with local installation codes and the requirements of the gas supplier and the manufacturer's Installation Instructions.

Installer's Guide

| Direct Vent Terminal Clearances | | | |
|---------------------------------|--|--|---|
| | | Canadian Installations | US Installations |
| A= | Clearance above grade, veranda, porch, deck, or balcony | 12 inches (30 cm) | 12 inches (30 cm) |
| B= | Clearance to window or door that may be opened | 6 inches (15 cm) for appliances \leq 10,000 Btuh (3 kw), 12 inches (30 cm) for appliances > 10,000 Btuh (3 kw) and \leq 100,000 Btuh (30 kw), 36 inches (91 cm) for appliances > 100,000 Btuh (30 kw) | 6 inches (15 cm) for appliances \leq 10,000 Btuh (3 kw), 9 inches (23 cm) for appliances > 10,000 Btuh (3 kw) and \leq 50,000 Btuh (15 kw), 12 inches (30 cm) for appliances > 50,000 Btuh (15 kw) |
| C= | Clearance to permanently closed window | * | * |
| D= | Vertical clearance to ventilated soffit located above the terminal within a horizontal distance of 2 feet (61 cm) from the center line of the terminal | * | * |
| E= | Clearance to unventilated soffit | * | * |
| F= | Clearance to outside corner | * | * |
| G= | Clearance to inside corner | * | * |
| H= | Clearance to each side of center line extended above meter/regulator assembly | 3 feet (91 cm) with a height 15 feet (4.5 m) above the meter/regulator assembly | * |
| I= | Clearance to service regulator vent outlet | 3 feet (91 cm) | * |
| J= | Clearance to nonmechanical air supply inlet to building or the combustion air inlet to any other appliance | 6 inches (15 cm) for appliances \leq 10,000 Btuh (3 kw), 12 inches (30 cm) for appliances > 10,000 Btuh (3 kw) and \leq 100,000 Btuh (30 kw), 36 inches (91 cm) for appliances > 100,000 Btuh (30 kw) | 6 inches (15 cm) for appliances \leq 10,000 Btuh (3 kw), 9 inches (23 cm) for appliances > 10,000 Btuh (3 kw) and \leq 50,000 Btuh (15 kw), 12 inches (30 cm) for appliances > 50,000 Btuh (15 kw) |
| K= | Clearance to a mechanical air supply inlet | 6 feet (1.83m) | 3 feet (91 cm) above if within 10 feet (3m) horizontally |
| L= | Clearance above a paved sidewalk or paved driveway located on public property | 7 feet (2.13 m) † | * |
| M= | Clearance under veranda, porch, deck, or balcony | 12 inches (30 cm) ‡ | * |

Notes:
 1. In accordance with the current CSA B149.1 Natural Gas and Propane Installation Code.
 2. In accordance with the current ANSI Z223.1/NFPA 54 National Fuel Gas Code.
 †. A vent shall not terminate directly above a sidewalk or paved driveway that is located between two single family dwelling and serves both dwellings.
 ‡. Permitted only if veranda, porch, deck, or balcony is fully open on a minimum of two sides beneath the floor.
 * Clearance in accordance with local installation codes and the requirements of the gas supplier and the manufacturer's Installation Instructions.

Figure 26

DOWNWARD VENTING

Furnace may be in vertical or horizontal configuration.

All horizontal pipes must be supported at maximum of 3 foot intervals

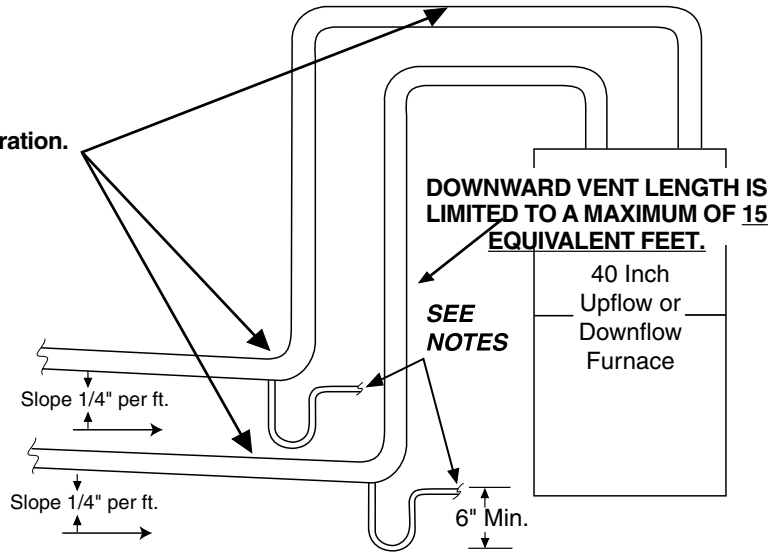

NOTES:

- A) Condensate trap for vent pipe must be a minimum of 6 inches in height.
- B) Condensate trap for vent and inlet pipe must be connected into a condensate drain pump; an open or vented drain; or it can be connected to the outlet hose of the Furnace condensate trap. Outdoor draining of the Furnace and coil condensate is permissible if allowed by local codes.

⚠ CAUTION

⚠ CAUTION

Caution should be taken to prevent drains from freezing or causing slippery conditions that could lead to personal injury. Excessive draining of condensate may cause saturated ground conditions that may result in damage to plants.

- C) The condensate trap should be primed at initial start up prior to heating season operation.

IMPORTANT:

The Commonwealth of Massachusetts requires compliance with regulation 248 CMR 4.00 and 5.00 for installation of through – the – wall vented gas appliances as follows:

For all side wall horizontally vented gas fueled equipment installed in every dwelling, building or structure used in whole or in part for residential purposes, including those owned or operated by the Commonwealth and where the side wall exhaust vent termination is less than seven (7) feet above finished grade in the area of the venting, including but not limited to decks and porches, the following requirements shall be satisfied:

1. **INSTALLATION OF CARBON MONOXIDE DETECTORS.** At the time of installation of the side wall horizontal vented gas fueled equipment, the installing plumber or gasfitter shall observe that a hard wired carbon monoxide detector with an alarm and battery back-up is installed on the floor level where the gas equipment is to be installed. In addition, the installing plumber or gasfitter shall observe that a battery operated or hard wired carbon monoxide detector with an alarm is installed on each additional level of the dwelling, building or structure served by the side wall horizontal vented gas fueled equipment. It shall be the responsibility of the property owner to secure the services of qualified licensed professionals for the installation of hard wired carbon monoxide detectors

a. In the event that the side wall horizontally vented gas fueled equipment is installed in a crawl space or an attic, the hard wired carbon monoxide detector with alarm and battery back-up may be installed on the next adjacent floor level.

b. In the event that the requirements of this subdivision can not be met at the time of completion of installation, the owner shall have a period of thirty (30) days to comply with the above requirements; provided, however, that during said thirty (30) day period, a battery operated carbon monoxide detector with an alarm shall be installed.

2. **APPROVED CARBON MONOXIDE DETECTORS.** Each carbon monoxide detector as required in accordance with the above provisions shall comply with NFPA 720 and be ANSI/UL 2034 listed and IAS certified.

3. **SIGNAGE.** A metal or plastic identification plate shall be permanently mounted to the exterior of the building at a minimum height of eight (8) feet above grade directly in line with the exhaust vent terminal for the horizontally vented gas fueled heating appliance or equipment. The sign shall read, in print size no less than one-half (1/2) inch in size, "GAS VENT DIRECTLY BELOW. KEEP CLEAR OF ALL OBSTRUCTIONS".

4. **INSPECTION.** The state or local gas inspector of the side wall horizontally vented gas fueled equipment shall not approve the installation unless, upon inspection, the inspector observes carbon monoxide detectors and signage installed in accordance with the provisions of 248 CMR 5.08(2)(a)1 through 4.

This appliance requires a special venting system. If BAYAIR30AVENTA or BAYVENT200B are used, a copy of the installation instructions for the kit shall remain with the appliance or equipment at the completion of installation. The venting system installation instructions can be obtained from the manufacturer by writing to the following address:

American Standard, Inc.
6200 Troup Highway
Tyler, TX 75707
Attention: Manager of Field Operations Excellence

Installer's Guide

CONDENSATE DRAIN INSTRUCTIONS

⚠ WARNING

CARBON MONOXIDE POISONING HAZARD

Failure to follow the installation instructions for the venting system being placed into operation could result in carbon monoxide poisoning or death.

⚠ CAUTION

It is recommended that a drain pan be installed under the furnace to prevent property damage, or personal injury.

Knock outs are provided on the left and right hand side of both furnace cabinets for drain connections *IN VERTICAL APPLICATIONS*. The standard arrangement is for the drain connection on the left side. The tubing may have to be trimmed in this application to avoid kinking.

The **upflow (vertical application)** has provisions for right side drain connections by turning the trap and extending the tubing to the lower right front corner of the Furnace. Trim all excess tubing to avoid kinking. The connecting tubing for left or right side condensate drain shown in Figure 27 is shipped in the blower compartment.

It is always recommended that an auxiliary drain pan be installed under a horizontally installed evaporator or 90% Gas Furnace. Connect the auxiliary drain line to a separate drain line (no trap is needed in this line).

All horizontal applications are left side only and require repositioning the condensate canister trap to the exterior of the cabinet. Additionally the drain tubing connected to the inducer housing must be repositioned for removing the plug and re-connecting the tubing to the lower connection on the inducer housing. See Figure 28.

For horizontal installation, remove the condensate trap and position the trap outside the cabinet through the slotted opening next to the secondary cell. On upflow/horizontal models, remove lines from the blower section and pull through the blower deck. Cut and reattach the line from the secondary cell (use the spring to prevent kinking).

The inducer housing has a secondary drain opening at its 9 o'clock position. Remove the plug and use the plug to cover the hole at the 6 o'clock position. Reposition the Inducer drain tube from 6 o'clock to the 9 o'clock location. Cut and reattach the tube to the canister trap. Plug openings in Blower deck, Inducer and Blower section. See Figure 28.

Connections must be made to an **OPEN/ VENTED DRAIN**.

NOTE: Use 1/2" size PVC pipe and fittings throughout for drain connections (fittings, pipe and PVC solvent cement not provided).

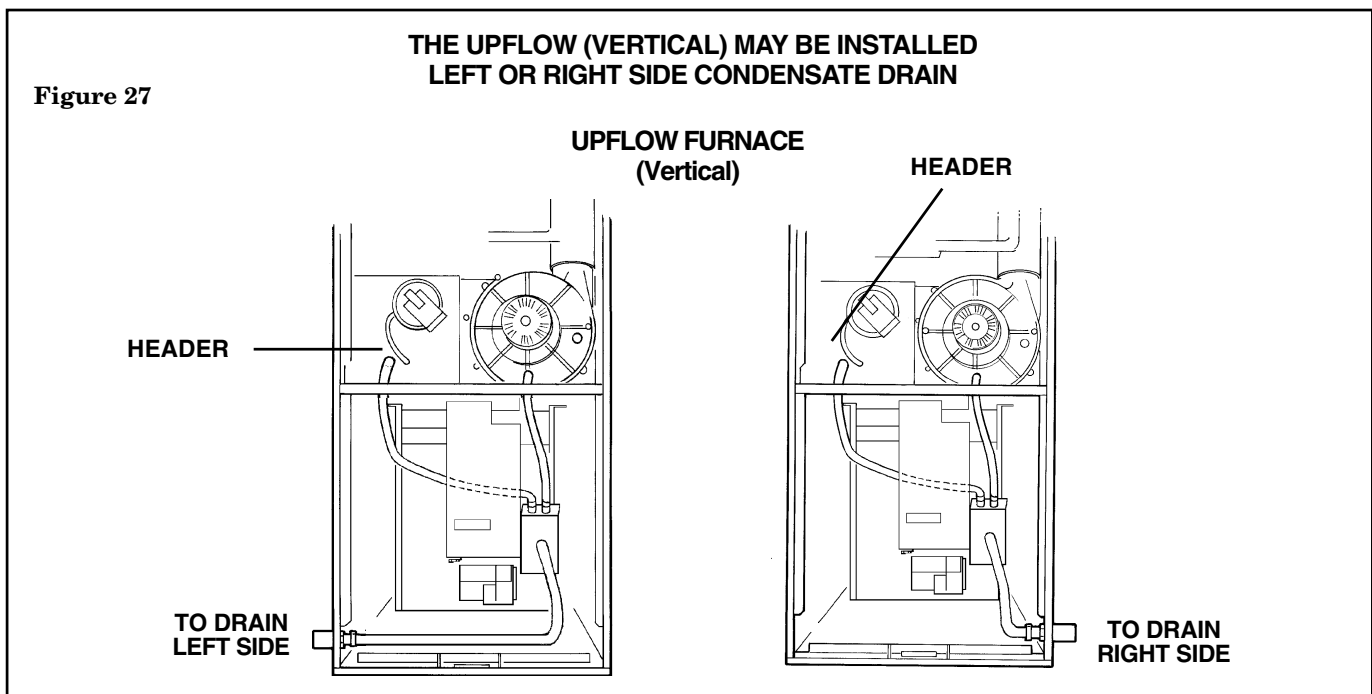
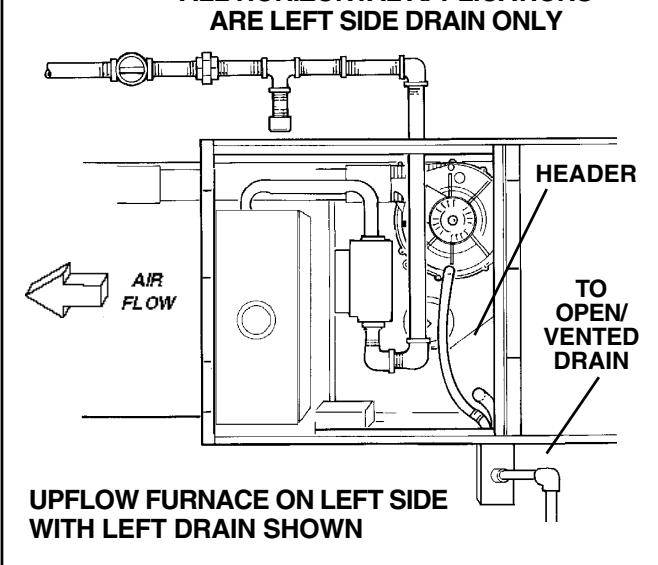

Figure 28 ALL HORIZONTAL APPLICATIONS ARE LEFT SIDE DRAIN ONLY



NOTE: A corrosion resistant condensate pump must be used if a pump is required for a specific drain system.

IMPORTANT:

The condensate drain should be installed with provisions to prevent winter freeze-up of the condensate drain line. Frozen condensate will block drains, resulting in furnace shutdown. If the drain line cannot be installed in a conditioned space and/ or its surrounding ambient temperature is expected to fall below freezing, then heat tape should be applied as required to prevent freezing (per manufacturer's instructions). The heat tape should be rated at 5 or 6 watts per foot at 120 volts. Self-regulating (preferred) or thermostatically controlled heat tape is required.

Typical sources of UL listed heat tapes are W.W. Granger, Inc. (Wintergard Plus™ Series), McMaster Carr Supply Co. (3554 Series), or your equipment supplier.

The condensate drain may be cleaned or inspected by removal of the drain tube at the header.

Figure 29

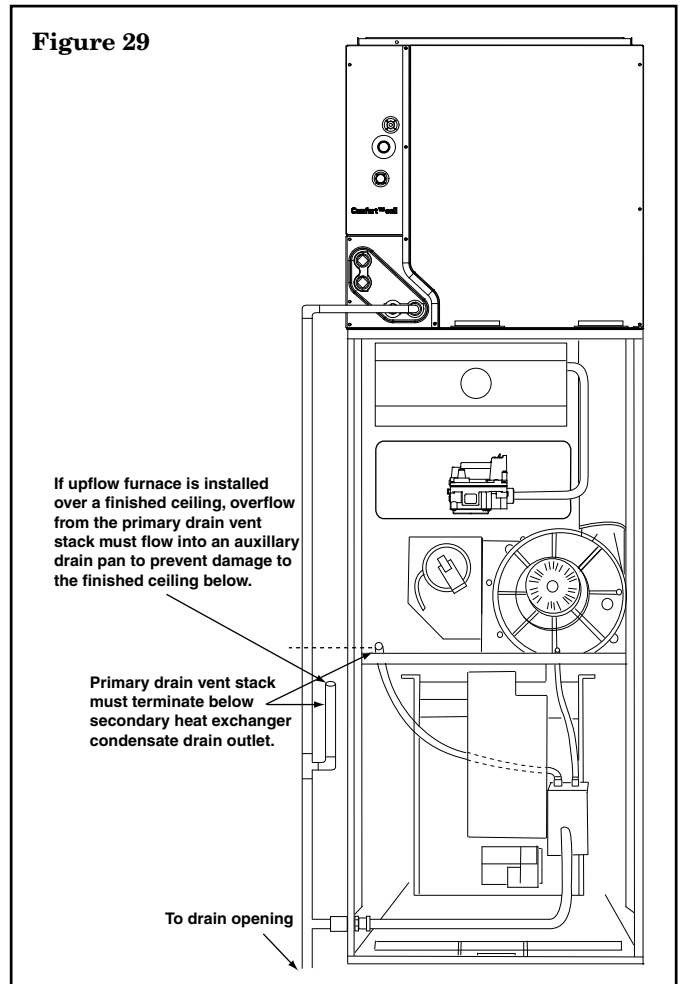

Evaporator and Furnace condensate drain piping may be manifolded together as shown in Figure 29. A primary drain vent stack must be installed and terminated below the outlet of the secondary heat exchanger drain connection to prevent water from damaging Furnace controls if the primary drain outlet plugs up.

Where the Furnace is installed above a finished ceiling, the primary drain vent stack must be installed such that overflow from the vent stack opening will flow into an auxiliary drain pan in order to prevent water damage to the finished ceiling below.

Installer's Guide

FIELD WIRING DIAGRAM FOR VARIABLE SPEED 2 STAGE FURNACE 1 STAGE HEATING USING A 1 STAGE HEATING THERMOSTAT NO COOLING

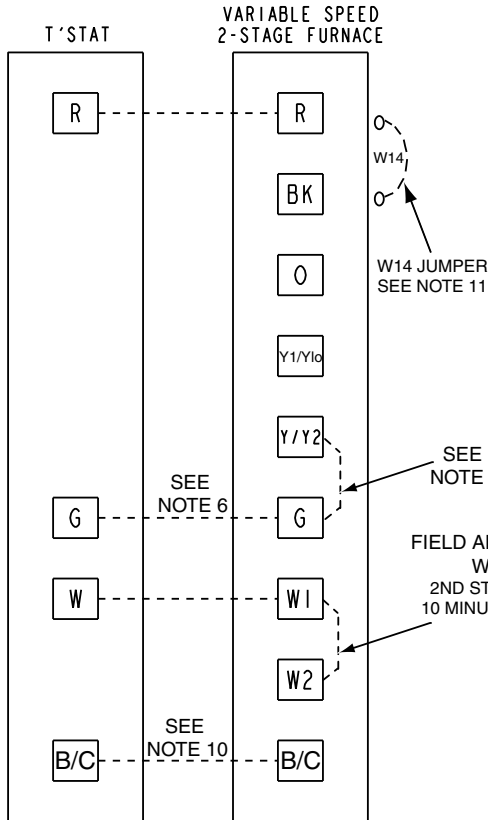

1. Be sure power agrees with equipment nameplates.
2. Low voltage (24 volt wiring) to be No. 18 A.W.G. min.
3. Grounding of equipment must comply with local codes.
4. Set thermostat heat anticipator per unit wiring diagram.
5. These leads provide 115V. power for connection of humidifier MAX. load 1.0 amp.
6. When a single stage heating thermostat without fan switch is used, no wiring on "G" terminal is used.
7. W1 and W2 must be jumpered together for proper operation. Second stage heat will begin 10 minutes after first stage.
8. Set dip switches with power off per installation instructions to set airflow and indoor fan off delays.
9. Continuous fan airflow can be increased by adding this jumper.
10. This wire is only for thermostats requiring connection to transformer common terminal.
11. Optional humidistat is to be connected between R and BK. Factory installed jumper R to BK on the circuit board must be cut if optional humidistat is used. The jumper must also be cut when applying an airflow command signal to the BK input such as with the variable speed single-zone and multi-zone system controllers. On single speed cooling only/non-heat pump systems, jumper Y to O for proper operation of the delay profiles and the humidistat. For two compressor or two speed systems, jumper YLo to O.

INTER-COMPONENT WIRING

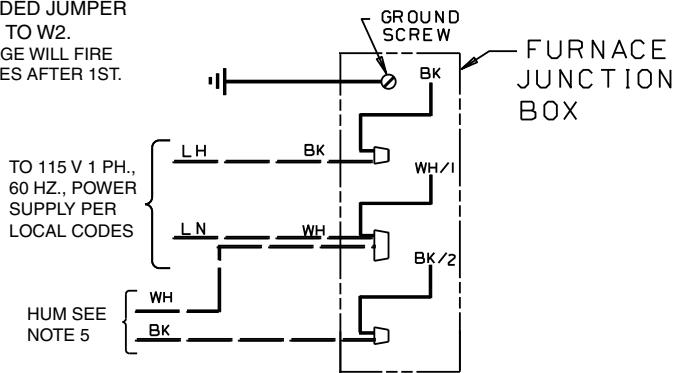
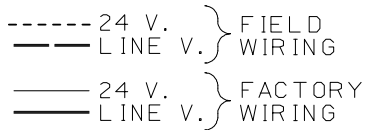

From Dwg. B342027 Rev. 0

FIELD WIRING DIAGRAM FOR VARIABLE SPEED 2 STAGE FURNACE 2 STAGE HEATING USING A 2 STAGE HEATING THERMOSTAT NO COOLING

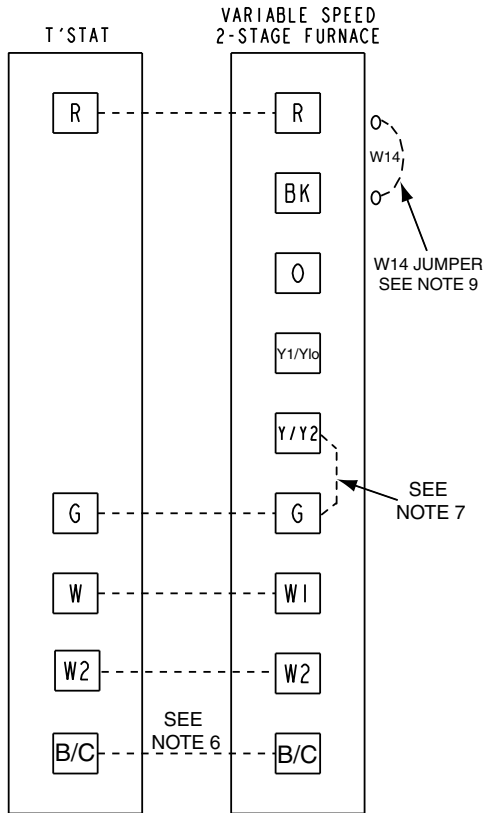

INTER-COMPONENT WIRING

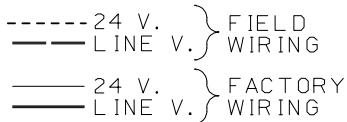

1. Be sure power agrees with equipment nameplates.
2. Low voltage (24 volt wiring) to be No. 18 A.W.G. min.
3. Grounding of equipment must comply with local codes.
4. Set thermostat heat anticipator per unit wiring diagram.
5. These leads provide 115V. power for connection of humidifier MAX. load 1.0 amp.
6. This wire is only for thermostats requiring connection to transformer common terminal.
7. Continuous fan airflow can be increased by adding this jumper.
8. Set dip switches with power off per installation instructions to set airflow and indoor fan off delays.
9. Optional humidistat is to be connected between R and BK. Factory installed jumper R to BK on the circuit board must be cut if optional humidistat is used. The jumper must also be cut when applying an airflow command signal to the BK input such as with the variable speed single-zone and multi-zone system controllers. On single speed cooling only/non-heat pump systems, jumper Y to O for proper operation of the delay profiles and the humidistat. For two compressor or two speed systems, jumper YLo to O.

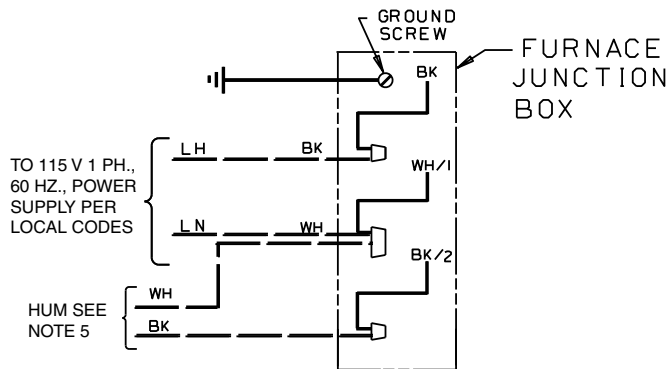

From Dwg. B342025 Rev. 0

Installer's Guide

FIELD WIRING DIAGRAM FOR VARIABLE SPEED 2 STAGE FURNACE 1 STAGE HEATING, 1 STAGE COOLING USING A 1 STAGE HEATING, 1 STAGE COOLING THERMOSTAT (OUTDOOR SECTION WITHOUT TRANSFORMER)

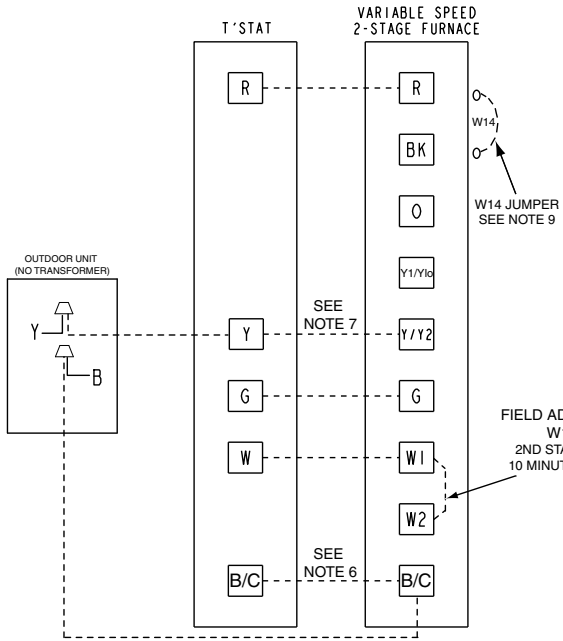

NOTES:

1. BE SURE POWER AGREES WITH EQUIPMENT NAMEPLATE(S)
2. LOW VOLTAGE (24 V. WIRING) TO BE NO. 18 A.W.G. MIN.
3. GROUNDING OF EQUIPMENT MUST COMPLY WITH LOCAL CODES.
4. SET THERMOSTAT HEAT ANTICIPATOR PER UNIT WIRING DIAGRAM.
5. THESE LEADS PROVIDE 115 V. POWER FOR CONNECTION OF THE HUMIDIFIER MAX. LOAD 1.0 AMPS EACH.
6. THIS WIRE IS ONLY FOR THERMOSTATS REQUIRING CONNECTION TO TRANSFORMER COMMON TERMINAL.
7. THE "Y" TERMINAL FROM THE THERMOSTAT MUST BE WIRED TO THE "Y" TERMINAL OF THE FURNACE CONTROL FOR PROPER BLOWER OPERATION DURING COOLING.
8. SET DIP SWITCHES WITH POWER OFF PER INSTALLATION INSTRUCTIONS TO SET AIRFLOW AND INDOOR FAN OFF DELAYS.
9. OPTIONAL HUMIDISTAT IS TO BE CONNECTED BETWEEN R AND BK. FACTORY INSTALLED JUMPER R TO BK ON THE CIRCUIT BOARD MUST BE CUT IF OPTIONAL HUMIDISTAT IS USED. THE JUMPER MUST ALSO BE CUT WHEN APPLYING AN AIRFLOW COMMAND SIGNAL TO THE BK INPUT SUCH AS WITH THE VARIABLE SPEED SINGLE-ZONE AND MULTI-ZONE SYSTEM CONTROLLERS. ON SINGLE SPEED COOLING ONLY/NON-HEAT PUMP SYSTEMS, JUMPER Y TO O FOR PROPER OPERATION OF THE DELAY PROFILES AND THE HUMIDISTAT. FOR TWO COMPRESSOR OR TWO SPEED SYSTEMS, JUMPER YLO TO O.

FIELD ADDED JUMPER
W1 TO W2.
2ND STAGE WILL FIRE
10 MINUTES AFTER 1ST.

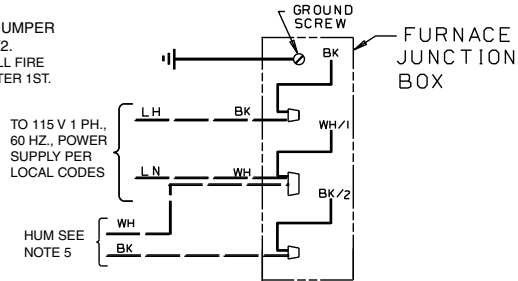

INTER-COMPONENT WIRING

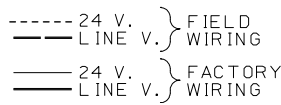

From drawing B342022 Rv 0

**FIELD WIRING DIAGRAM FOR VARIABLE SPEED 2 STAGE FURNACE
2 STAGE HEATING, 1 STAGE COOLING
USING A 2 STAGE HEATING, 1 STAGE COOLING THERMOSTAT
(OUTDOOR SECTION WITHOUT TRANSFORMER)**

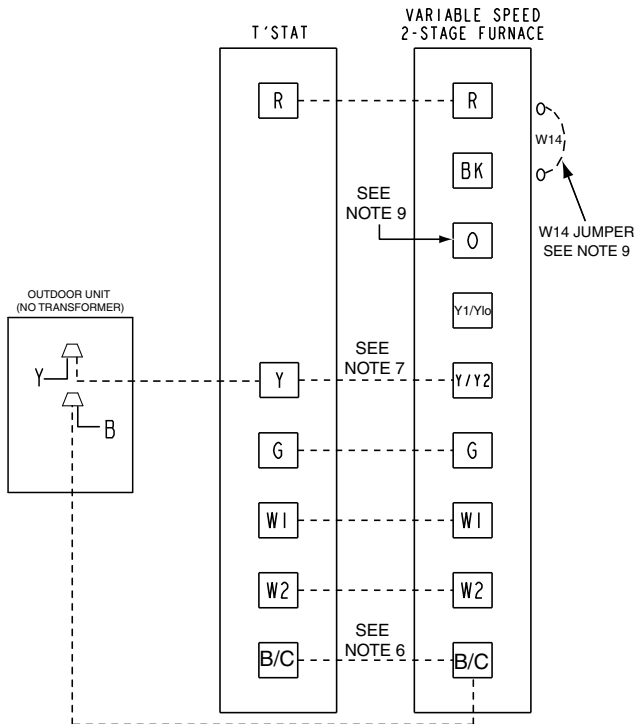

- NOTE:**
- 1.) BE SURE POWER AGREES WITH EQUIPMENT NAMEPLATE(S).
 - 2.) LOW VOLTAGE (24V. WIRING) TO BE NO. 18AWG MIN.
 - 3.) GROUNDING OF EQUIPMENT MUST COMPLY WITH LOCAL BUILDING CODES.
 - 4.) SET THERMOSTAT HEAT ANTICIPATOR PER UNIT WIRING DIAGRAM.
 - 5.) THESE LEADS PROVIDE 115V. POWER FOR CONNECTION OF THE HUMIDIFIER. MAX. LOAD 1.0 AMPS EACH.
 - 6.) THIS WIRE IS ONLY FOR THERMOSTATS REQUIRING CONNECTION TO TRANSFORMER COMMON TERMINAL.
 - 7.) THE "Y" TERMINAL FROM THE THERMOSTAT MUST BE WIRED TO THE "Y" TERMINAL OF THE FURNACE CONTROL FOR PROPER BLOWER OPERATION DURING COOLING.
 - 8.) SET DIP SWITCHES WITH POWER OFF PER INSTALLATION INSTRUCTIONS TO SET AIRFLOW AND INDOOR FAN OFF DELAYS.
 - 9.) OPTIONAL HUMIDISTAT IS TO BE CONNECTED BETWEEN "R" AND "BK". FACTORY INSTALLED JUMPER "R" TO "BK" ON THE CIRCUIT BOARD MUST BE CUT IF OPTIONAL HUMIDISTAT IS USED. THE JUMPER MUST ALSO BE CUT WHEN APPLYING AN AIRFLOW COMMAND SIGNAL TO THE "BK" INPUT SUCH AS WITH THE VARIABLE SPEED SINGLE-ZONE AND MULTI-ZONE SYSTEM CONTROLLERS. ON SINGLE SPEED COOLING ONLY / NON-HEAT PUMP SYSTEMS, JUMPER "Y" TO "O" FOR PROPER OPERATION OF THE DELAY PROFILES AND THE HUMIDISTAT. FOR TWO COMPRESSOR OR TWO SPEED SYSTEMS, JUMPER "YLO" TO "O".

INTER - COMPONENT WIRING

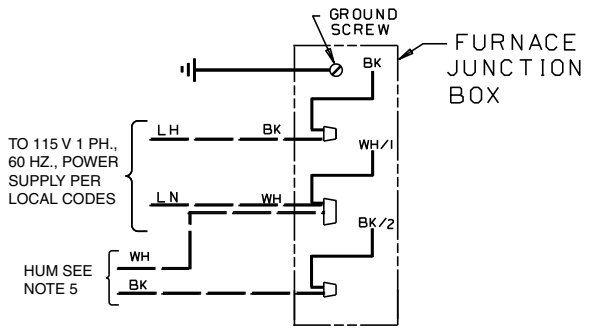
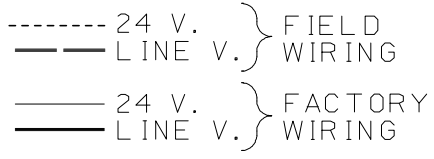

From Dwg. B342020 Rev. 0

Installer's Guide

FIELD WIRING DIAGRAM FOR VARIABLE SPEED 2 STAGE FURNACE 2 STAGE HEATING, 2 STAGE COOLING (OUTDOOR SECTION WITHOUT TRANSFORMER)

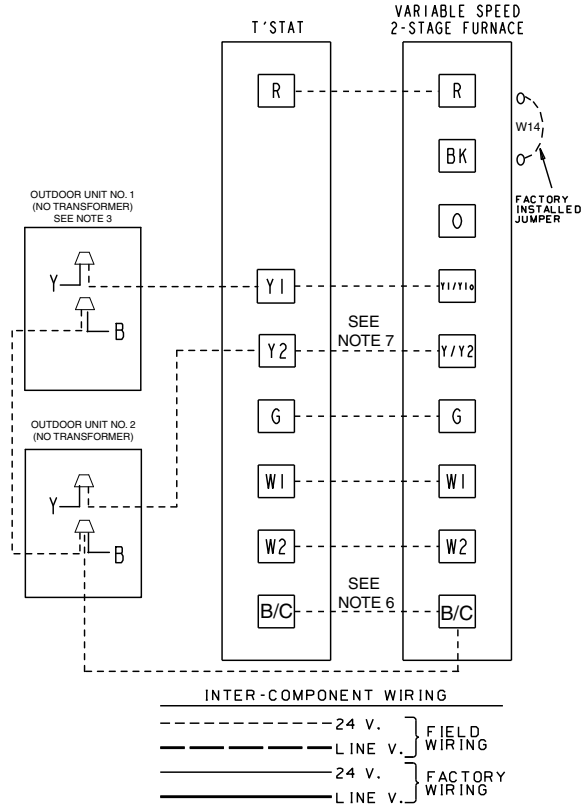

NOTES:

1. BE SURE POWER AGREES WITH EQUIPMENT NAMEPLATE(S)
2. LOW VOLTAGE(24 V. WIRING) TO BE NO. 18 A.W.G. MIN.
3. GROUNDING OF EQUIPMENT MUST COMPLY WITH LOCAL CODES.
4. SET THERMOSTAT HEAT ANTICIPATOR PER UNIT WIRING DIAGRAM.
5. THESE LEADS PROVIDE 115 V. POWER FOR CONNECTION OF THE HUMIDIFIER MAX. LOAD 1.0 AMPS EACH.
6. THIS WIRE IS ONLY FOR THERMOSTATS REQUIRING CONNECTION TO TRANSFORMER COMMON TERMINAL.
7. THE "Y2" TERMINAL FROM THE THERMOSTAT MUST BE WIRED TO THE "Y" TERMINAL OF THE FURNACE CONTROL FOR PROPER BLOWER OPERATION DURING COOLING.
8. SET DIP SWITCHES WITH POWER OFF PER INSTALLATION INSTRUCTIONS TO SET AIRFLOW AND INDOOR FAN OFF DELAYS.
9. OPTIONAL HUMIDISTAT IS TO BE CONNECTED BETWEEN R AND BK. FACTORY INSTALLED JUMPER R TO BK ON THE CIRCUIT BOARD MUST BE CUT IF OPTIONAL HUMIDISTAT IS USED. THE JUMPER MUST ALSO BE CUT WHEN APPLYING AN AIRFLOW COMMAND SIGNAL TO THE BK INPUT SUCH AS WITH THE VARIABLE SPEED SINGLE-ZONE AND MULTI-ZONE SYSTEM CONTROLLERS, ON SINGLE SPEED COOLING ONLY/NON-HEAT PUMP SYSTEMS. JUMPER Y TO O FOR PROPER OPERATION OF THE DELAY PROFILES AND THE HUMIDISTAT. FOR TWO COMPRESSOR OR TWO SPEED SYSTEMS, JUMPER YLO TO O.

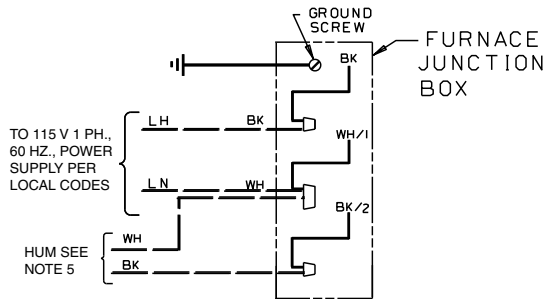

From Dwg. B342018 Rev. 0

HUMIDISTAT HOOKUP

If an optional Humidistat is to be connected between "R" and "BK", the factory installed jumper between "R" and "BK" on the circuit board must be cut. If an optional Humidistat is used, the jumper must also be cut when applying an airflow command signal to the "BK" input such as with the variable speed single-zone and multi-zone system controller. On single speed cooling only/non-heat pump systems, jumper "Y" to "O" for proper operation of the delay profiles and the Humidistat. For two compressor or two speed systems, jumper "Ylo" to "O".

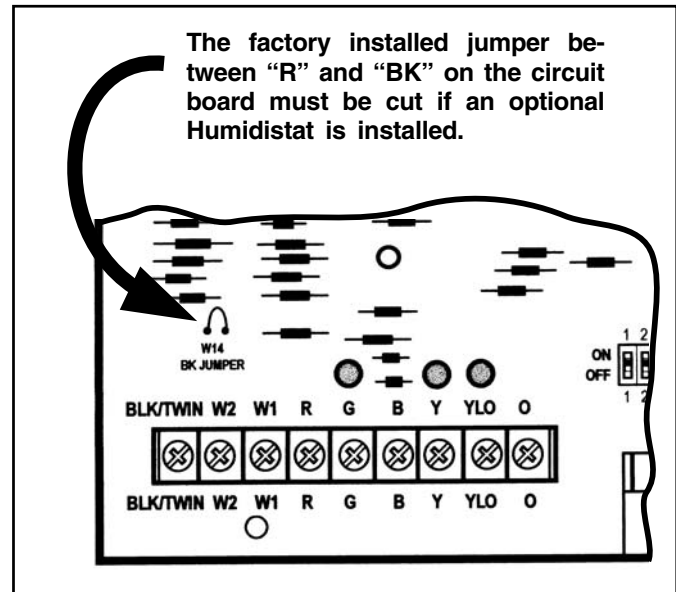

ELECTRICAL CONNECTIONS

Make wiring connections to the unit as indicated on enclosed wiring diagram. As with all gas appliances using electrical power, this Furnace shall be connected into a permanently live electric circuit. It is recommended that Furnace be provided with a separate "circuit protection device" electric circuit. The Furnace must be electrically grounded in accordance with local codes or in the absence of local codes with the National Electrical Code, ANSI/NFPA 70 or CSA C22.1 Electrical Code, if an external electrical source is utilized. **The integrated Furnace control is polarity sensitive.** The hot leg of the 120V power supply must be connected to the black power lead as indicated on the wiring diagram. Provision for hooking up a humidifier is provided on the integrated control.

Refer to the SERVICE FACTS literature and unit wiring diagram attached to furnace.

GAS PIPING

WARNING

DO NOT USE SEMI-RIGID METALLIC GAS CONNECTORS (FLEXIBLE GAS LINES) WITHIN THE FURNACE CABINET.

FAILURE TO FOLLOW THIS WARNING COULD RESULT IN PROPERTY DAMAGE, PERSONAL INJURY OR DEATH.

The following warning complies with State of California law, Proposition 65.

WARNING

Hazardous Gases!

Exposure to fuel substances or by-products of incomplete fuel combustion is believed by the state of California to cause cancer, birth defects, or other reproductive harm.

WARNING

EXPLOSION HAZARD!

PROPANE GAS IS HEAVIER THAN AIR AND MAY COLLECT IN ANY LOW AREAS OR CONFINED SPACES. IF THE GAS FURNACE IS INSTALLED IN A BASEMENT, AN EXCAVATED AREA OR A CONFINED SPACE, IT IS STRONGLY RECOMMENDED TO CONTACT A GAS SUPPLIER TO INSTALL A GAS DETECTING WARNING DEVICE IN CASE OF A GAS LEAK.

NOTE: The manufacturer of your furnace does NOT test any detectors and makes no representations regarding any brand or type of detector.

WARNING

ODORANT FADE MAY MAKE THE GAS UNDETECTABLE EXCEPT WITH A WARNING DEVICE. IF THE GAS FURNACE IS INSTALLED IN A BASEMENT, AN EXCAVATED AREA OR A CONFINED SPACE, IT IS STRONGLY RECOMMENDED TO CONTACT A GAS SUPPLIER TO INSTALL A GAS DETECTING WARNING DEVICE IN CASE OF A GAS LEAK.

NOTE: The manufacturer of your furnace does not test any detectors and makes no representations regarding any brand or type of detector.

**TABLE 6
NATURAL GAS ONLY**

| PIPE SIZE | LENGTH OF PIPE | | | | | | |
|-----------|----------------|-----|-----|-----|-----|-----|-----|
| | 10 | 20 | 30 | 40 | 50 | 60 | 70 |
| 1/2 | 132 | 92 | 73 | 63 | 56 | 50 | 46 |
| 3/4 | 278 | 190 | 152 | 130 | 115 | 105 | 96 |
| 1 | 520 | 350 | 285 | 245 | 215 | 195 | 180 |
| 1-1/4 | 1050 | 730 | 590 | 520 | 440 | 400 | 370 |

This table is based on pressure drop of 0.3 inch W.C. and 0.6 SP.GR. gas

**TABLE 7
ORIFICE SIZES**

| INPUT RATING BTUH | NUMBER OF BURNERS | MAIN BURNER ORIFICE DRILL SIZE | |
|-------------------|-------------------|--------------------------------|--------|
| | | NAT. GAS | LP GAS |
| 60,000 | 3 | 45 | 56 |
| 80,000 | 4 | 45 | 56 |
| 100,000 | 5 | 45 | 56 |
| 120,000 | 6 | 45 | 56 |

CAUTION

Use a backup wrench on the Gas Valve when installing gas piping to prevent damage to the Gas Valve and Manifold Assembly.

The installation of piping shall be in accordance with piping codes and the regulations of the local gas company. Pipe joint compound must be resistant to the chemical reaction with liquefied petroleum gases.

Refer to piping Table 6, for delivery sizes. Connect gas supply to the unit, using a ground joint union and a manual shut-off Valve as shown in Figure 31. National codes require a condensation drip leg to be installed ahead of the controls as shown in Figures 31 & 32.

The Furnace and its individual shut-off valve must be disconnected from the gas supply piping system during any pressure testing of that system at test pressures in excess of 1/2 psig (3.5 kPa).

The Furnace must be isolated from the gas supply piping by closing its individual manual shut-off Valve during any pressure testing of the gas supply piping system at test pressures equal to or less than 1/2 psig (3.5 kPa).

NOTE: Maximum pressure to the Gas Valve for natural gas is 13.8" W.C. Minimum pressure is 5.0" W.C. Maximum pressure to the Gas Valve for propane is 13.8" W.C. Minimum pressure is 11.0" W.C.

All gas fittings must be checked for leaks using a soapy solution before lighting the Furnace. **DO NOT CHECK WITH AN OPEN FLAME!**

Installer's Guide

Figure 30

AUTOMATIC GAS VALVE WITH MANUAL SHUTOFF

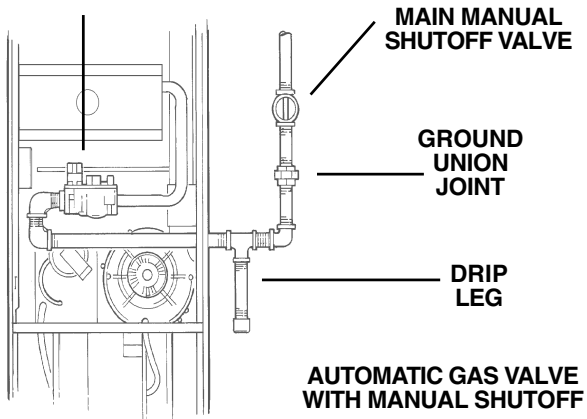

MAIN MANUAL SHUTOFF VALVE

GROUND UNION JOINT

DRIP LEG

AUTOMATIC GAS VALVE WITH MANUAL SHUTOFF

UPFLOW MAY BE LEFT OR RIGHT HAND GAS PIPING

AUTOMATIC GAS VALVE WITH MANUAL SHUTOFF

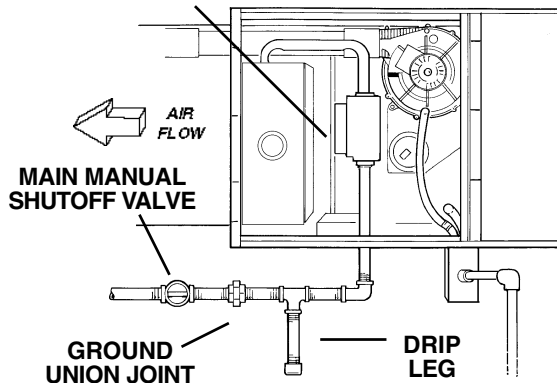

MAIN MANUAL SHUTOFF VALVE

GROUND UNION JOINT

DRIP LEG

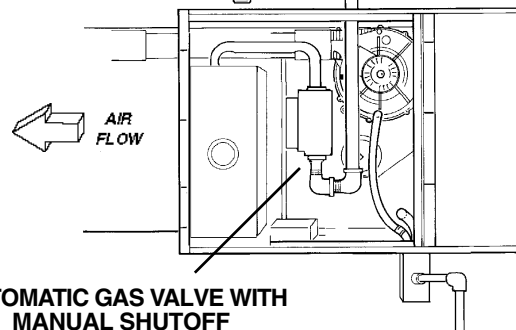

AUTOMATIC GAS VALVE WITH MANUAL SHUTOFF

HORIZONTAL FURNACE GAS PIPING MAY BE FROM EITHER SIDE
(Typical UPFLOW Furnace in horizontal configuration shown)

Figure 31

COMBUSTION AND INPUT CHECK (See also High Altitude Derate)

⚠ WARNING

Replace and/ or tighten all plugs removed or loosened when adjusting gas pressure. Leak check the fittings before placing the Furnace into regular service. Failure to follow this warning could result in fire, explosion, property damage, or death.

1. Make sure all gas appliances are off except the Furnace.
2. Clock the gas meter with the Furnace operating (determine the dial rating of the meter) for one revolution.
3. Match the "Sec" column in the gas flow (in cfh) Table 8 with the time clocked.
4. Read the "Flow" column opposite the number of seconds clocked.
5. Use the following factors if necessary:
 For 1 Cu. Ft. Dial Gas Flow CFH =
 Chart Flow Reading \div 2
 For 1/2 Cu Ft. Dial Gas Flow CFH =
 Chart Flow Reading \div 4
 For 5 Cu. Ft. Dial Gas Flow CFH =
 10X Chart Flow Reading \div 4
6. Multiply the final figure by the heating value of the gas obtained from the utility company and compare to the nameplate rating. This must not exceed the nameplate rating.
7. Changes can be made by adjusting the Manifold Pressure (See Table 9), or changing orifices (orifice change may not always be required). To adjust the Manifold Pressure:
 - a. Turn off all electrical power to the system.
 - b. Attach a Manifold Pressure gauge to the outlet pressure tap marked "OUT PRESS TAP" on White-Rodgers gas valve model 36G. (see Figure 33 for White-Rodgers gas valve model 36G). Attach flexible tubing and a Manometer to the barbed fitting. For the Gas Valve model 36G, do not remove the pressure tap test screw. Loosen the pressure tap test screw one turn and install flexible tubing and a Manometer directly onto the outlet pressure boss.
 - c. The other side of the Manifold Pressure Gauge must be referenced to the Burner Box as shown in Figure 32.
 - d. Turn on system power and energize Valve.
 - e. For the White-Rodgers Gas Valve model 36G:
 1. Adjust low fire by removing the low adjustment regulator cover screw (See Figure 33).
 2. To increase outlet pressure, turn the regulator adjust screw clockwise. To decrease outlet pressure, turn the regulator adjust screw counter-clockwise. Adjust regulator until pressure shown on Manometer matches the pressure specified in Table 9.
 3. Replace and tighten the regulator cover screw securely.
 4. Cycle the Valve several times to verify regulator setting.
 5. Adjust high fire by removing the high adjustment regulator cover screw (See Figure 33).

Figure 32

CORRECT METHOD OF CHECKING DIRECT VENT MANIFOLD PRESSURE WITH BURNER BOX REFERENCED

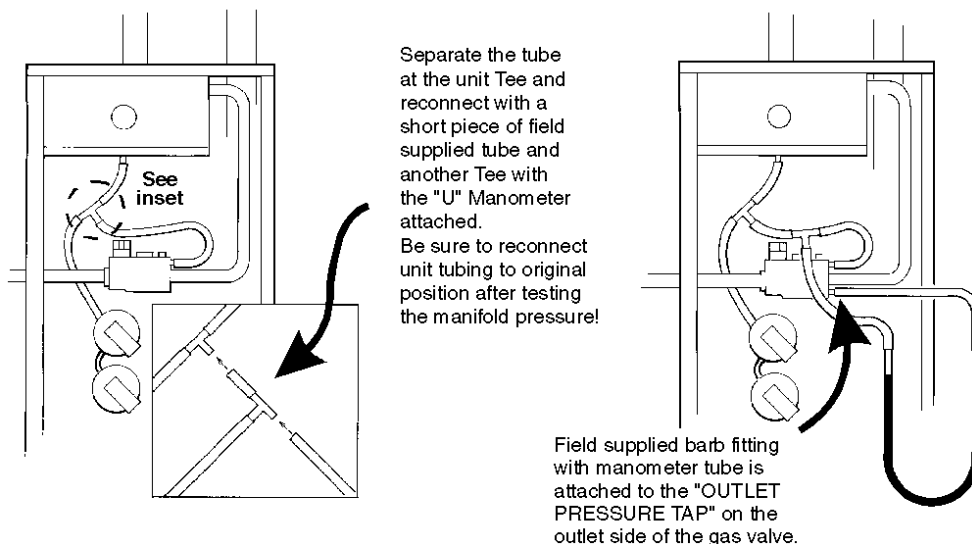

⚠ CAUTION: Return all tubing, caps, and/or plugs to original positions when pressure checks are completed.

Installer's Guide

6. To increase outlet pressure, turn the regulator adjust screw clockwise. To decrease outlet pressure, turn the regulator adjust screw counter-clockwise. The final Manifold Pressure setting shall be as specified in Table 9 with an input of no more than nameplate rating and no less than 93% of the nameplate rating, unless the unit is derated for high altitude.
7. Replace high adjustment regulator cover screw and tighten securely.
8. Cycle the Valve several times to verify regulator setting.
- g. Turn off all electrical power to the system.
- h. Remove the Manometer and flexible tubing. Remove the barbed fitting and replace the plug or tighten the pressure test screw.
- i. Turn on electrical power to the system and energize valve.
- j. Using a leak detection solution or soap suds, check for leaks at plug or pressure boss screw.

NOTE: The Manifold Pressure must be referenced to the Burner Box. The Burner Box pressure tap equalizes the Gas Valve pressure regulator. Manifold Pressure is checked by installing a tee (field supplied) in the tubing, between the tee coming from the Burner Box tube and the Gas Valve, in addition to the regular Gas Valve pressure tap on the outlet side of the Gas Valve. See Figure 32.

Table 7 lists the main burner orifices used with the Furnace. If a change of orifices is required to correct the Furnace input rating refer to Table 10.

REINSTALLATION OF THE BURNER BOX COVER

Figure 34 shows the correct way to reinstall the Burner Box cover if adjustment or replacement of the flame sensor, hot surface igniter, or main burner orifices have required removal of the cover.

HIGH ALTITUDE DERATE

Input ratings (BTUH) of these Furnaces are based on sea level operation and should not be changed at elevations up to 2,000 ft.

If the installation is 2,000 ft. or above, the Furnace input rate (BTUH) shall be reduced 4% for each 1,000 ft. above sea level.

Installation of this furnace at altitudes above 2,000 ft. (610m) shall be in accordance with local codes, or in the absence of local codes, the *National Fuel Gas Code, ANSI Z223.1/ NFPA 54* or *National Standard of Canada, Natural Gas and Propane Installation Code, CSA B149.1*. Installation of this furnace at altitudes above 2,000 ft. (610m) shall be made in accordance with the listed high Altitude Conversion Kit available with this furnace.

The Furnace input rate shall be checked by clocking the gas flow rate (CFH) and multiplying by the heating value obtained from the local utility supplier for the gas being delivered at the installed altitude. Input rate changes can be made by adjusting the Manifold Pressure (min 3.0 - max 3.7 in. W.C. - Natural Gas) or changing orifices (orifice change may not always be required).

If the desired input rate can not be achieved with a change in Manifold Pressure, then the orifices must be changed. LP installations will require an orifice change.

IMPORTANT:

Reinstall the propane orifices to the same depth as the orifices supplied with the equipment.

TABLE 8

| GAS FLOW IN CUBIC FEET PER HOUR | | | | | | | |
|---------------------------------|------|------|------|------|------|------|------|
| 2 CUBIC FOOT DIAL | | | | | | | |
| SEC. | FLOW | SEC. | FLOW | SEC. | FLOW | SEC. | FLOW |
| 8 | 900 | 29 | 248 | 50 | 144 | 82 | 88 |
| 9 | 800 | 30 | 240 | 51 | 141 | 84 | 86 |
| 10 | 720 | 31 | 232 | 52 | 138 | 86 | 84 |
| 11 | 655 | 32 | 225 | 53 | 136 | 88 | 82 |
| 12 | 600 | 33 | 218 | 54 | 133 | 90 | 80 |
| 13 | 555 | 34 | 212 | 55 | 131 | 92 | 78 |
| 14 | 514 | 35 | 206 | 56 | 129 | 94 | 76 |
| 15 | 480 | 36 | 200 | 57 | 126 | 96 | 75 |
| 16 | 450 | 37 | 195 | 58 | 124 | 98 | 73 |
| 17 | 424 | 38 | 189 | 59 | 122 | 100 | 72 |
| 18 | 400 | 39 | 185 | 60 | 120 | 104 | 69 |
| 19 | 379 | 40 | 180 | 62 | 116 | 108 | 67 |
| 20 | 360 | 41 | 176 | 64 | 112 | 112 | 64 |
| 21 | 343 | 42 | 172 | 66 | 109 | 116 | 62 |
| 22 | 327 | 43 | 167 | 68 | 106 | 120 | 60 |
| 23 | 313 | 44 | 164 | 70 | 103 | 124 | 58 |
| 24 | 300 | 45 | 160 | 72 | 100 | 128 | 56 |
| 25 | 288 | 46 | 157 | 74 | 97 | 132 | 54 |
| 26 | 277 | 47 | 153 | 76 | 95 | 136 | 53 |
| 27 | 267 | 48 | 150 | 78 | 92 | 140 | 51 |
| 28 | 257 | 49 | 147 | 80 | 90 | 144 | 50 |

TABLE 9

| FINAL MANIFOLD PRESSURE SETTINGS (inches w.c.) | | |
|--|----------------|----------------|
| FUEL | 2nd Stage Max. | 1st Stage Max. |
| NATURAL GAS | 3.5" W.C. | 1.7" W.C. |
| LP GAS | 10.5" W.C. | 6.0" W.C. |

See Table 10 for help in selecting orifices if orifice change is required. Furnace input rate and temperature rise should be checked again after changing orifices to confirm the proper rate for the altitude.

The vent length table on page 14 shows the required vent lengths for installations at various altitudes. An optional high altitude kit is available for installations above 5000 feet. Installations above 12,000 feet are not allowed.

**TABLE 10
PART NUMBERS FOR REPLACEMENT ORIFICES**

| DRILL SIZE | PART NUMBER | DRILL SIZE | PART NUMBER |
|------------|-------------|------------|-------------|
| 44 | ORF00501 | 54 | ORF00555 |
| 45 | ORF00644 | 55 | ORF00693 |
| 46 | ORF00909 | 56 | ORF00907 |
| 47 | ORF00910 | 57 | ORF00908 |
| 48 | ORF01099 | 58 | ORF01338 |
| 49 | ORF00503 | 59 | ORF01339 |
| 50 | ORF00493 | | |

Turn the main Gas Valve toggle switch (See Figures 30 & 31) within the unit to the “OFF” position. Turn the external gas valve to “ON”. Purge the air from the gas lines. After purging, check all gas connections for leaks with a soapy solution -- **DO NOT CHECK WITH AN OPEN FLAME**. Allow 5 minutes for any gas that might have escaped to dissipate.

LP Gas being heavier than air may require forced ventilation. Turn the toggle switch on the Gas Valve in the unit to the “ON” position.

START-UP AND ADJUSTMENT

PRELIMINARY INSPECTIONS

⚠ WARNING

Disconnect power to the unit before removing the blower door. Allow a minimum of 15 seconds for IFC power supply to discharge to 0 volts. Failure to follow this warning could result in property damage, personal injury or death.

With gas and electrical power “OFF”

1. Duct connections are properly sealed
2. Air cleaner and filters(if applicable) are in place
3. Venting is properly assembled
4. Blower door is in place

TABLE 11

| Orifice Twist Drill Size If Installed At Sea Level | ALTITUDE ABOVE SEA LEVEL and Orifice Required At Other Elevations | | | | | | | | | |
|--|--|------|------|------|------|------|------|------|-------|--|
| | 2000 | 3000 | 4000 | 5000 | 6000 | 7000 | 8000 | 9000 | 10000 | |
| 42 | 42 | 43 | 43 | 43 | 44 | 44 | 45 | 46 | 47 | |
| 43 | 44 | 44 | 44 | 45 | 45 | 46 | 47 | 47 | 48 | |
| 44 | 45 | 45 | 45 | 46 | 47 | 47 | 48 | 48 | 50 | |
| 45 | 46 | 47 | 47 | 47 | 48 | 48 | 49 | 49 | 50 | |
| 46 | 47 | 47 | 47 | 48 | 48 | 49 | 49 | 50 | 51 | |
| 47 | 48 | 48 | 49 | 49 | 49 | 50 | 50 | 51 | 52 | |
| 54 | 54 | 55 | 55 | 55 | 55 | 55 | 56 | 56 | 56 | |
| 55 | 55 | 55 | 55 | 56 | 56 | 56 | 56 | 56 | 57 | |
| 56 | 56 | 56 | 57 | 57 | 57 | 58 | 59 | 59 | 60 | |
| 57 | 58 | 59 | 59 | 60 | 60 | 61 | 62 | 63 | 63 | |
| 58 | 59 | 60 | 60 | 61 | 62 | 62 | 63 | 63 | 64 | |

From National Fuel Gas Code - Table F-4

Figure 33

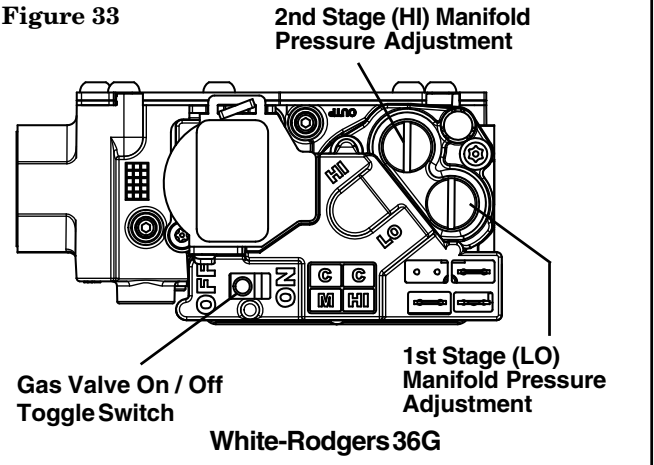

LIGHTING INSTRUCTIONS

⚠ WARNING

DO NOT ATTEMPT TO MANUALLY LIGHT THE BURNER. FAILURE TO FOLLOW THIS WARNING COULD RESULT IN PROPERTY DAMAGE, PERSONAL INJURY OR DEATH.

⚠ CAUTION

If this is done during the cold weather months, provisions must be taken to prevent freeze-up of all water pipes and water receptacles.

Figure 34

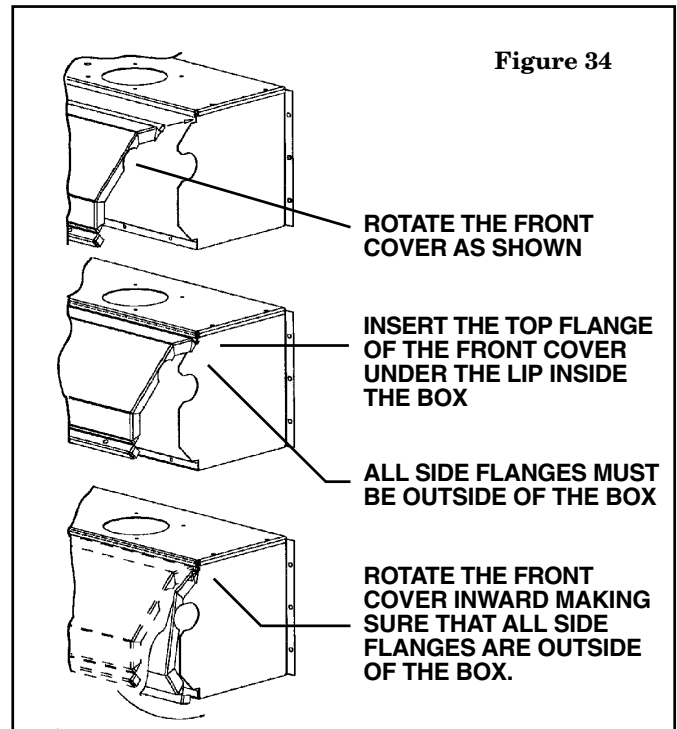

Lighting instructions appear on each unit. Each installation must be checked out at the time of initial start up to insure proper operation of all components. Check out should include putting the unit through one complete cycle as outlined below.

Installer's Guide

Turn on the main electrical supply and set the Comfort Control above the indicated temperature. The ignitor will automatically heat, then the Gas Valve is energized to permit the flow of gas to the burners. After ignition and flame is established, the flame control module monitors the flame and supplies power to the Gas Valve until the Comfort Control is satisfied.

To shut off.

For complete shutdown: Turn the gas cock knob on the main Gas Valve to the "OFF" position (See Figures 30 & 31). Disconnect the electrical supply to the unit.

SEQUENCE OF OPERATION

NOTE: *Whole House Air Cleaner is energized when blower is operating and there is a call for heat or cool. This can result in brief periods of blower operation with the whole house air cleaner off. This can occur during the heat fan off period or if the enhanced mode of operation is chosen for cooling.*

Comfort Control call for heat (2-Stage Comfort Control)

Call for 1st Stage only:

W1 Comfort Control contacts close signaling the control module to run its self-check routine. After the control module has verified that the 1st Stage Pressure Switch contacts are open and the Limit Switch(es) contacts are closed, the draft blower will be energized.

As the induced draft blower comes up to speed, the Pressure Switch contacts will close and the ignitor warm up period will begin. The ignitor will heat for approx. 20 seconds, then the Gas Valve is energized in 1st Stage to permit gas flow to the burners.

The flame sensor confirms that ignition has been achieved within the 4 second ignition trial period.

As the flame sensor confirms that ignition has been achieved, the delay to fan ON period begins timing and after approx. 45 seconds the indoor blower motor will be energized at low speed and will continue to run during the heating cycle. The whole house air cleaner will energize.

Call for 2nd Stage after 1st Stage:

W2 Comfort Control contacts close signaling a call for 2nd Stage Heat. After a 30 second delay, the induced draft blower will be energized on high speed and the 2nd Stage Pressure Switch contacts will close. The Gas Valve is energized in 2nd Stage and the indoor blower motor in high speed.

2nd Stage satisfied, 1st Stage still called:

W2 Comfort Control contacts open signaling that 2nd Stage Heating requirements are satisfied.

The induced draft blower is reduced to low speed allowing the 2nd Stage Pressure Switch contacts to open and the Gas Valve is reduced to 1st Stage. The indoor blower motor is reduced to low speed.

1st stage satisfied:

W1 Comfort Control contacts open signaling that 1st Stage heating requirements are satisfied. The Gas Valve will close and the induced draft blower and the whole house air cleaner will be de-energized. The indoor blower motor will continue to run for the fan off period (Field selectable at 60, 100, 140 or 180 seconds), then will be de-energized by the control module.

Comfort Control call for heat (1-Stage Comfort Control)

W1/ W2 (jumpered) Comfort Control contacts close signaling a call for heat. 1st Stage sequence of operation remains the same as above. 2nd Stage Heat will energize after the Stage delay timer (10 minutes) has expired.

Comfort Control satisfied:

W1/ W2 (jumpered) contacts close signaling the control module to close the Gas Valve. The induced draft blower is switched to low speed and de-energized after the post purge timer has expired. The indoor blower motor will continue to operate after the flames are extinguished and then is switched to low heat speed for the FAN-OFF period. The whole house air cleaner will be de-energized.

NOTE TO INSTALLER:

Review warnings and the contents of USER'S INFORMATION MANUAL with the homeowner when installation is complete and equipment is ready to be turned over to the homeowner for normal operation.

CONTROL AND SAFETY SWITCH ADJUSTMENT

LIMIT SWITCH CHECK OUT

The limit switch is a safety device designed to close the Gas Valve should the Furnace become overheated. Since proper operation of this switch is important to the safety of the unit, **it must be checked out on initial start up by the installer.**

To check for proper operation of the Limit Switches, set the Comfort Control to a temperature higher than the indicated temperature to bring on the Gas Valve. Restrict the airflow by blocking the return air or by disconnecting the blower. When the Furnace reaches the maximum outlet temperature as shown on the rating plate, the burners must shut off. If they do not shut off after a reasonable time and overheating is evident, a faulty Limit Switch is probable and the Limit Switch must be replaced. After checking the operation of the Limit Control, be sure to remove the paper or cardboard from the return air inlet, or reconnect the blower. Refer to the Service Facts for additional instructions.

INDOOR BLOWER TIMING

⚠ WARNING

DISCONNECT POWER TO THE UNIT BEFORE REMOVING THE BLOWER DOOR.

FAILURE TO FOLLOW THIS WARNING COULD RESULT IN PROPERTY DAMAGE, PERSONAL INJURY OR DEATH.

Heating: The Integrated Furnace Control (IFC) controls the Variable Speed Indoor Blower. The blower "on" time is fixed at 45 seconds after ignition. The FAN-OFF period is field selectable by dip switches #1 and #2 located on the Integrated Furnace Control between the 5-pin and 9-pin wire connectors. The delay may be set at 60, 100, 140, or 180 seconds. The factory setting is 100 seconds (See unit wiring diagram).

Cooling: The fan delay-off period is set by dip switches on the Integrated Furnace Control. The options for cooling delay off is field selectable by dip switches #5 and #6.

The following table and graph explain the delay-off settings:

TABLE 12 FAN OFF - DELAY OPTIONS

| SWITCH SETTINGS | | SELECTION | NOMINAL AIRFLOW |
|-----------------|---------|-----------------|-----------------|
| 5 - OFF | 6 - OFF | NONE | SAME |
| 5 - ON | 6 - OFF | 1.5 MINUTES | 100% * |
| 5 - OFF | 6 - ON | 3 MINUTES | 50% |
| 5 - ON | 6 - ON | Enhanced Mode** | 50 - 100% |

This unit is equipped with a blower door switch which cuts power to the blower and Gas Valve causing shut-down when the door is removed. Operation with the door removed or ajar can permit the escape of dangerous fumes. All panels must be securely closed at all times for safe operation of the Furnace.

* - *This setting is equivalent to BAY24X045 relay benefit.*

** - *This selection provides ENHANCED MODE, which is a ramping up and ramping down of the blower speed to provide improved comfort, quietness, and potential energy savings. See Wiring Diagram notes on the unit or in the Service Facts for complete wiring setup for ENHANCED MODE. The graph which follows, shows the ramping process.*

See Wiring Diagram on the unit or in the Service Facts for complete wiring setup for Enhanced Mode.

AIRFLOW ADJUSTMENT

⚠ WARNING

Disconnect power to the unit before removing the blower door. Allow a minimum of 15 seconds for IFC power supply to discharge to 0 volts.

Failure to follow this warning could result in property damage, personal injury or death.

⚠ WARNING

Operation with the door removed or ajar can permit the escape of dangerous fumes. All panels must be securely closed at all times for safe operation of the Furnace.

Failure to follow this warning could result in property damage, personal injury or death.

Check inlet and outlet air temperatures to make sure they are within the ranges specified on the Furnace rating nameplate. If the airflow needs to be increased or decreased, see the Service Facts for information on changing the speed of the blower motor.

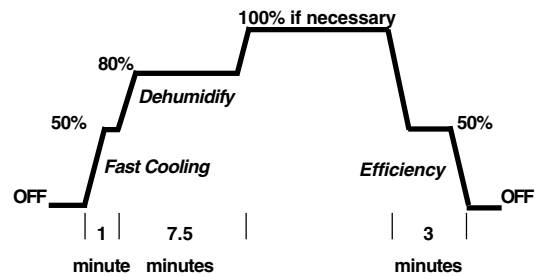

This unit is equipped with a blower door switch which cuts power to the blower and Gas Valve causing shut-down when the door is removed.

ROOM AIR COMFORT CONTROL HEAT ANTICIPATOR ADJUSTMENT

Set the Comfort Control heat anticipator according to the current flow measured, or the settings found in the notes on the Furnace wiring diagram (found in the SERVICE FACTS or inside the furnace casing).

INSTRUCTIONS TO THE OWNERS

In the event that electrical, fuel, or mechanical failures occur, the owner should immediately turn the gas supply off at the manual Gas Valve, located in the burner compartment. Also turn off electrical power to the Furnace and contact a qualified service technician.

BURNER BOX TEMPERATURE LIMIT DEVICE

All models are equipped with a manual reset temperature limit located on the Burner Box. In case of excessive temperature, the limit will open and cause the circuit to open which shuts off all flow of gas.

Installer's Guide

CONDITIONS THAT AFFECT SYSTEM OPERATION

1. EXCESSIVE COMBUSTION PRESSURE (WIND IN EXCESS OF 40 M.P.H.) VENT OR FLUE BLOCKAGE

On a call for heat, the Variable Speed Draft Inducer must first ramp up to speed and close the Pressure Switch before the ignition sequence is allowed to begin. If the Pressure Switch does not close, the motor will ramp up to maximum speed and continue to operate there for about 1 minute.

After one minute, the Integrated Furnace Control will turn the motor off for about 30 seconds and then back on in an attempt to reestablish proper operation. This condition is indicative of a highly restricted or blocked inlet or outlet vent pipe or a failed Pressure Switch.

If pressure against induced draft blower outlet becomes excessive, the Pressure Switch will open. If the Pressure Switch is open for more than 3.5 seconds, the variable speed draft inducer will speed up and attempt to close the Pressure Switch. If the Pressure Switch is not closed within 12 seconds or if the maximum speed of the motor is reached, the draft inducer sends a Fault signal to the Integrated Furnace Control. If the unit is operating in Second Stage, an Inducer Fault will cause the Furnace Control to transition the system to First Stage and it will operate there for 10 minutes before attempting to run again in Second Stage. If the unit is operating in First Stage, an Inducer Fault will cause the Furnace Control to shut the system down and wait 30 seconds before attempting to reestablish operation in First Stage.

2. LOSS OF FLAME

If loss of flame occurs during a heating cycle, or flame is not present at the sensor, the flame control module will close the Gas Valve. The Integrated Furnace Control will then recycle the ignition sequence, then if ignition is not achieved, it will shut off the Gas Valve and lock out the system.

3. POWER FAILURE

If there is a power failure during a heating cycle, the system will restart the ignition sequence automatically when power is restored, if the Comfort Control still calls for heat.

4. GAS SUPPLY FAILURE

If loss of flame occurs during a heating cycle, the system Integrated Control Module will recycle the ignition sequence, then if ignition is not achieved, the Integrated Control Module will shut off the Gas Valve and lock out the system.

5. INDUCED DRAFT BLOWER FAILURE

Please refer to the Variable Speed Draft Inducer troubleshooting manual for diagnostic assistance.

6. CONDENSATE DRAIN BLOCKAGE

If the condensate drain is blocked, either by debris, improper draining, or by freezing condensate, the Pressure Switch will sense the accumulation of condensate in the Furnace drain trap. The unit will not operate properly until the condensate drain has been cleared, and the condensate flows freely.

7. RESET AFTER LOCKOUT

When the Integrated Furnace Control has shut the system down and gone into lockout, the system must be manually reset before the unit will restart. The system can be reset by turning the system power off for more than 1 second, or by removing 24VAC from the control for more than 1 second, or by removing the Comfort Control call for heat for more than 1 second but less than 20 seconds.

8. RESET AFTER BURNER BOX LIMIT SHUTDOWN

If the Furnace shuts down, one thing that can be checked is the Burner Box temperature Limit Switch. It is located on the bottom of the Burner Box. The vent and combustion air inlet terminations should be checked for blockage. If blockage exists, clear the problem and then the reset button may be depressed. **If there is no blockage of the terminations, the Limit Switch must be reset by qualified service personnel.**

WHOLE HOUSE AIR CLEANER CHECKOUT

CAUTION

Before changing the position of the High Voltage selector switch on the High Voltage power supply, make sure the power has been removed from the furnace and the High Voltage power supply.

Check out the Furnace Whole House Air Cleaner installation in accordance with this instructions page 40. Adjust ozone setting if needed. See figure 38 on page 40.

NOTE: Whole House Air Cleaner is energized when blower is operating and there is a call for heat or cool. This can result in brief periods of blower operation with the whole house air cleaner off. This can occur during the heat fan off period or if the enhanced mode of operation is chosen for cooling.

WHOLE HOUSE AIR CLEANER MAINTENANCE

1. For maximum efficiency the COLLECTION CELL should be inspected and cleaned on a regular basis.

NOTE: A 30 to 90 day cleaning interval is normal for the COLLECTION CELL and should be adjusted based upon unit run time and the home environment.

2. The FIELD CHARGER must be removed and cleaned only by a qualified service professional.
3. The FIELD CHARGER must be cleaned at least once a year.
4. The FIELD CHARGER may require more frequent cleaning in homes with high indoor relative humidity (greater than 65% RH).
5. Consult your service professional about cleaning intervals.

WARNING

TO PREVENT INJURY OR DEATH DUE TO CONTACT WITH MOVING PARTS, TURN THE POWER TO THE FURNACE OFF BEFORE CLEANING OR SERVICING THE WHOLE HOUSE AIR CLEANER. FAILURE TO FOLLOW THIS WARNING COULD RESULT IN PROPERTY DAMAGE, PERSONAL INJURY OR DEATH.

WARNING

RISK OF ELECTRIC SHOCK: THESE SERVICING INSTRUCTIONS ARE FOR USE BY QUALIFIED PERSONNEL ONLY. TO REDUCE THE RISK OF ELECTRIC SHOCK, DO NOT PERFORM ANY SERVICING OTHER THAN THAT CONTAINED IN THESE OPERATING INSTRUCTIONS UNLESS YOU ARE QUALIFIED TO DO SO. FAILURE TO FOLLOW THIS WARNING COULD RESULT IN PROPERTY DAMAGE, PERSONAL INJURY OR DEATH.

CAUTION

High Voltage is present within the air cleaner for operation. Turn the power off and wait at least 15 seconds to allow voltage to discharge.

NOTE: System Information

Before cleaning the coil or ducts in the furnace, remove the COLLECTION CELL and FIELD CHARGER from the air cleaner. Chemicals used during the cleaning of the Furnace, or ductwork can damage the air cleaner components and degrade the performance of the air cleaner.

CLEANING THE COLLECTION CELL

1. Turn the air conditioning system off at the Comfort Control and turn off service disconnect.
2. Remove top furnace door.
3. Slide COLLECTION CELL out of Furnace.

CLEANING

The COLLECTION CELL may be cleaned either by vacuuming (recommended method) or by washing.

VACUUM CLEANING

Remove the COLLECTION CELL from the conditioned space before vacuuming. Vacuum both sides of the COLLECTION CELL to clean.

WASHING

Use low-pressure water spray, such as a sink sprayer or garden hose to clean the COLLECTION CELL. Some residue may require warm water to be removed.

- Do NOT use soap or detergent in cleaning the COLLECTION CELL.
- Do NOT immerse the COLLECTION CELL completely in water.
- Do NOT place the COLLECTION CELL into a dishwasher to clean.
- ALLOW THE COLLECTION CELL TO DRY THOROUGHLY BEFORE REINSTALLING.

Slightly tap the COLLECTION CELL to remove water retained in the filter. Allow the COLLECTION CELL to dry thoroughly before reinstalling.

CLEANING THE FIELD CHARGER

CAUTION

FIELD CHARGER PINS ARE SHARP. DO NOT BEND FIELD CHARGER PINS. WEAR APPROPRIATE GLOVES WHEN HANDLING THE FIELD CHARGER.

1. Turn off the Comfort Control and the service disconnect.
2. Turn off power to the Furnace and remove the top furnace door panel.
3. Remove COLLECTION CELL.
4. Remove the inner blower door panel by removing four screws.
5. Disconnect green return wire and red high voltage wire. To remove high voltage wire, twist and pull connector apart.
6. Remove the two 5/16" hold down screws at the front center.
7. Lift up the front of the FIELD CHARGER and slide forward to remove from the case. Lay the FIELD CHARGER on a secured flat surface.
8. Wipe down the face Plate of the FIELD CHARGER with a dry shop towel or use a vacuum cleaner. Do not disassemble the FIELD CHARGER.

Installer's Guide

NOTE: Do NOT use water, soap, detergent, or chemicals to clean the FIELD CHARGER.

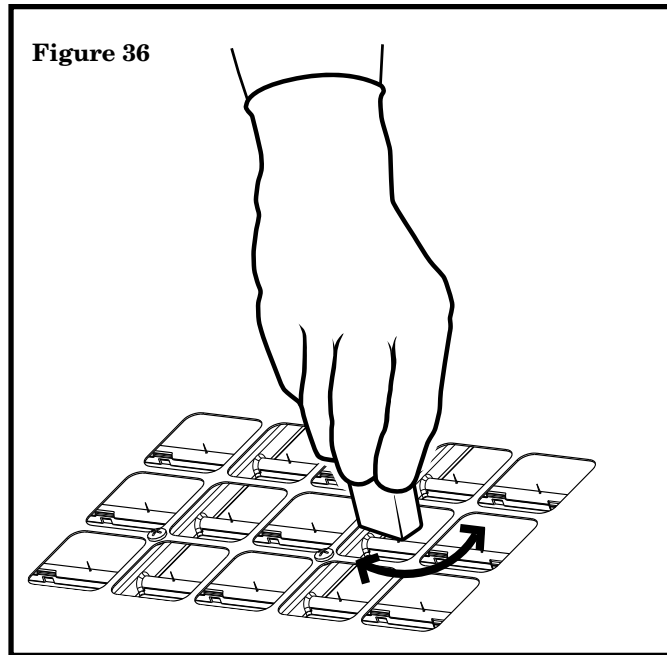
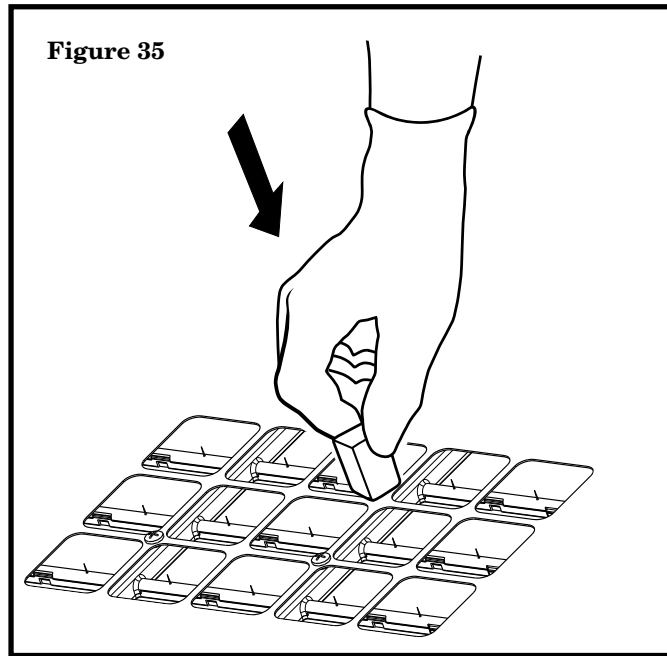

9. To clean pins, push a block of foam down over the FIELD CHARGER Pin.
10. Rotate the foam block on the FIELD CHARGER Pin.
11. Use the foam block to clean the faceplate opening edges.
12. Repeat steps 9 and 10 for each FIELD CHARGER Pin.
13. Reverse steps to reassemble the air cleaner. The inner blower door **MUST** be reinstalled.

INDOOR MOTOR MAINTENANCE

NOTE: Direct drive motors have bearings which are permanently lubricated and under normal use, lubrication is not recommended.

ROOM AIR COMFORT CONTROL HEAT ANTICIPATOR ADJUSTMENT

Set the Comfort Control heat anticipator according to the current flow measured, or the settings found in the notes on the Furnace wiring diagram (found inside the Furnace casing).

Also turn off electrical power to the Furnace and contact the service agency designated by your dealer.

⚠ WARNING

Should overheating occur, or the gas supply fail to shut off, shut off the Gas Valve to the unit before shutting off the electrical supply.

Failure to follow this warning could result in property damage, personal injury, or death.

⚠ WARNING

Failure to follow safety warnings exactly, could result in a fire or explosion causing property damage, personal injury or loss of life.

- Do not store or use gasoline or other flammable vapors and liquids in the vicinity of this or any other appliance.
- **WHAT TO DO IF YOU SMELL GAS**
 - Do not try to light any appliance.
 - Do not touch any electrical switch; do not use any phone in your building.
 - Immediately call your gas supplier from a neighbor's phone. Follow the gas supplier's instructions.
 - If you cannot reach your gas supplier, call the fire department.
- Installation and service must be performed by a qualified installer, service agency or the gas supplier.

The following warning complies with State of California law, Proposition 65.

 **WARNING**

This product contains fiberglass wool insulation!

Fiberglass dust and ceramic fibers are believed by the State of California to cause cancer through inhalation. Glasswool fibers may also cause respiratory, skin, or eye irritation.

PRECAUTIONARY MEASURES

- Avoid breathing fiberglass dust.
- Use a NIOSH approved dust/mist respirator.
- Avoid contact with the skin or eyes. Wear long-sleeved, loose-fitting clothing, gloves, and eye protection.
- Wash clothes separately from other clothing: rinse washer thoroughly.
- Operations such as sawing, blowing, tear-out, and spraying may generate fiber concentrations requiring additional respiratory protection. Use the appropriate NIOSH approved respirator in these situations.

FIRST AID MEASURES

Eye Contact – Flush eyes with water to remove dust. If symptoms persist, seek medical attention.

Skin Contact – Wash affected areas gently with soap and warm water after handling.

INTEGRATED FURNACE CONTROL RED LED "ERROR" FLASH CODES

| | |
|--------------------------------------|---|
| 2 Flashes --- | System Lockout (Retries or Recycles exceeded) |
| 3 Flashes --- | Draft Pressure Error - Possible problems: a) Venting problem b) Pressure switch problem c) Inducer problem |
| 4 Flashes --- | Open Temperature Limit Switch |
| 5 Flashes --- | Flame sensed when no flame should be present |
| 6 Flashes --- | 115 volt AC power reversed, ignitor (Triac) fault, poor grounding or system voltage too low |
| 7 Flashes --- | Gas valve circuit error |
| 8 Flashes --- | Low flame sense |
| 9 Flashes --- | Open Inducer Limit switch |
| 10 Flashes --- | Inducer communication error |
| Solid --- | Internal GV error or Low TH voltage |
| Solid Red w/Solid Green "STATUS" LED | Continuous Reset caused by a blown fuse or internal error. |

Installer's Guide

FAULT CODE RECOVERY

On power up, last 4 Faults, if any, will be flashed on the Red LED. The newest Fault detected will flash first and the oldest last. There will be a 2 second delay between Fault Code flashes. Solid Red LED error codes will not be displayed.

The Green LED will be on solid during last Fault Recovery. At any other time the control is powered, the Green LED indicator light will operate as shown in Table 13 and the Red LED will flash LitePort data (one flash) every 20 seconds.

**TABLE 13
NATURAL GAS ONLY**

| TABLE OF CUBIC FEET PER HOUR OF GAS FOR VARIOUS PIPE SIZES AND LENGTHS | | | | | | | |
|--|----------------|-----|-----|-----|-----|-----|-----|
| PIPE SIZE | LENGTH OF PIPE | | | | | | |
| | 10 | 20 | 30 | 40 | 50 | 60 | 70 |
| 1/2 | 132 | 92 | 73 | 63 | 56 | 50 | 46 |
| 3/4 | 278 | 190 | 152 | 130 | 115 | 105 | 96 |
| 1 | 520 | 350 | 285 | 245 | 215 | 195 | 180 |
| 1-1/4 | 1050 | 730 | 590 | 520 | 440 | 400 | 370 |

This table is based on pressure drop of 0.3 inch W.C. and 0.6 SP.GR. gas

Fault Code Reset

The last 4 Fault Codes can be erased from memory by powering up the control with "G" energized and then applying "R" to the "W1" terminal 3 times within 6 seconds. The control will acknowledge the reset by turning on the Red LED for 2 seconds.

Figure 37

***UX2/ DX2 Integrated Furnace Control**

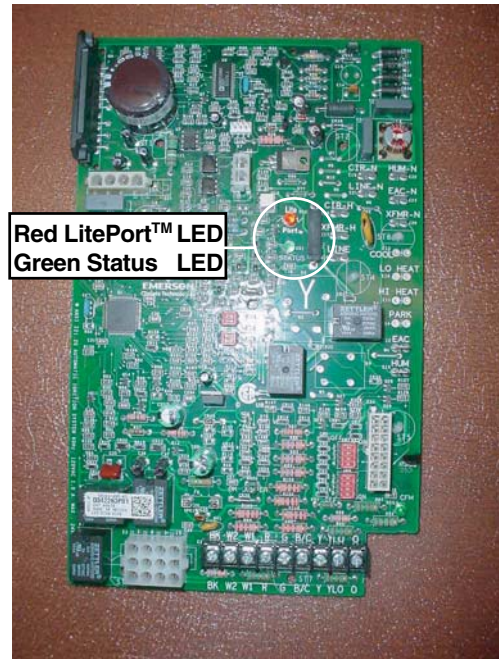

NOTE: In normal operation, the furnace makes a slight sound as the air passes through and is cleaned. In some applications, you may notice this sound coming from the return air vent(s). If desired, this sound level can be reduced with minimal impact on air cleaning efficiency by reducing the power setting of the FIELD CHARGER. The unit is shipped with the power set at 9.6KV (high). If sound is heard, reduce power level to 8.0KV (low) at the switch on the power supply. See Figure 38.

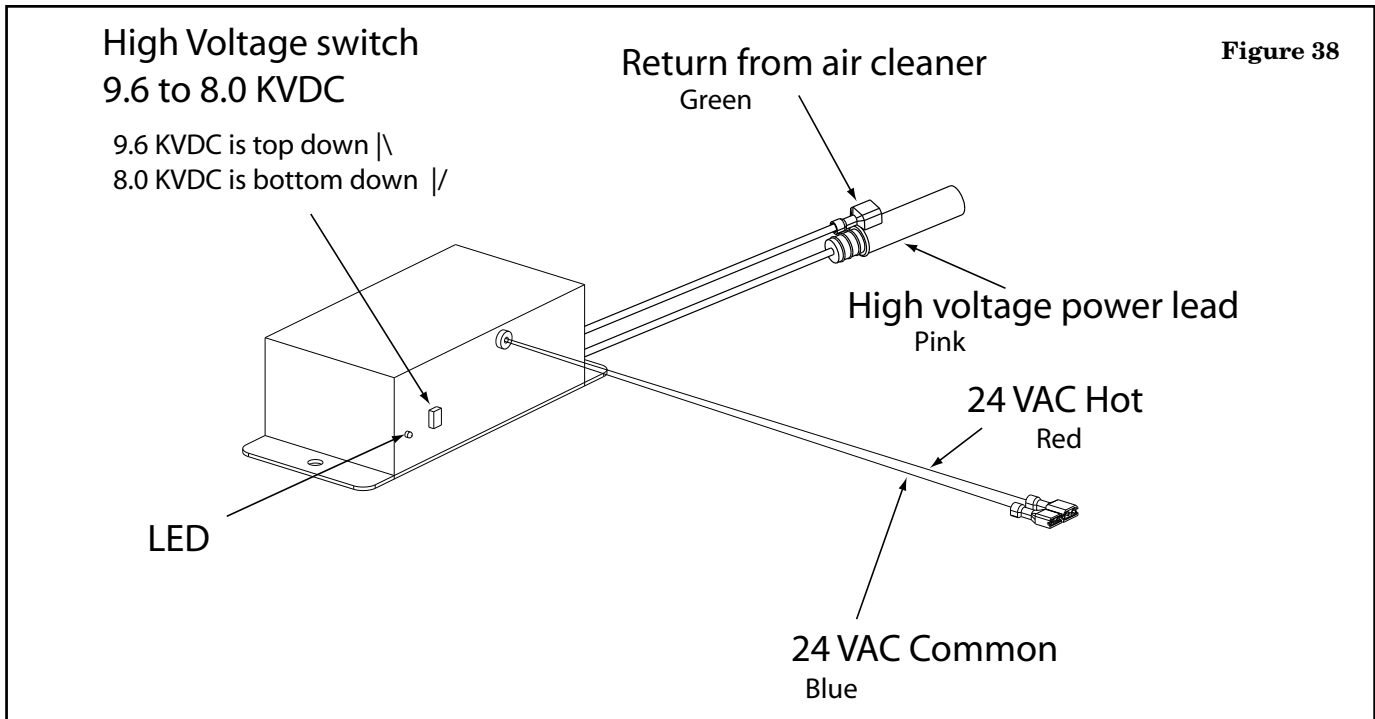

Figure 38

CHECKOUT PROCEDURES

After installation has been completed, it is recommended that the Furnace be checked against the following checklist.

1. Make sure power is "OFF" at power disconnect switch..... []
2. Check all field wiring for tight connections. See that grounding of unit is in accord with code. []
3. Make sure unit suspension (if used) is secure and that there are no tools or loose debris in, around or on top of the unit..... []
4. Check all duct outlets; they must be open and unrestricted []
5. Check drain lines and be sure all joints are tight []
6. Make sure secondary drain pan is installed []
7. Check power supply for correct requirements per unit nameplate []
8. Energize the system and carefully observe its operation; make any necessary adjustment []
9. Adjust ozone setting, if needed []
10. Instruct owner on proper operating procedure and leave Use and Care Manual with owner []
11. Check the Whole House Air Cleaner power output by the Green LED illumination. If the LED is on, this indicates High Voltage output to the air cleaner. []
 - a) Turn the Comfort Control to fan only.
 - b) Remove blower door panel.

⚠ WARNING

**RISK OF ELECTRICAL SHOCK:
ELECTRICAL POWER IS PRESENT FOR THE
NEXT 2 STEPS. THESE STEPS SHOULD BE
PERFORMED ONLY BY QUALIFIED PERSON-
NEL.**

**FAILURE TO FOLLOW THIS WARNING COULD
RESULT IN PERSONAL INJURY, ELECTRICAL
SHOCK, OR DEATH.**

- c) Depress blower door switch.
- d) Verify with Fan running that Green LED is illuminated.
- e) Release Blower Door Switch and put Blower Door back on.
- f) Turn Comfort Control to desired position.



Literature Order Number 18-CD25D1-2

File Number 18-CD25D1-2

Supersedes 18-CD25D1-1

Date 03/08

3/08

Trane
6200 Troup Highway
Tyler, TX 75707

For more information contact
your local dealer (distributor)

Since the manufacturer has a policy of continuous product and product data improvement, it reserves the right
to change design and specifications without notice.